

4

3

2

1

REVISIONS			
A	DESCRIPTION	DATE	INITIALES
	CREATION		

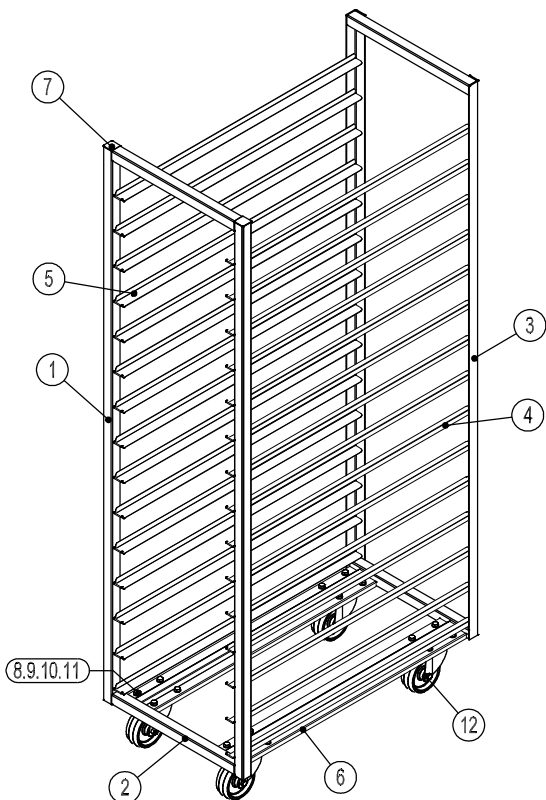
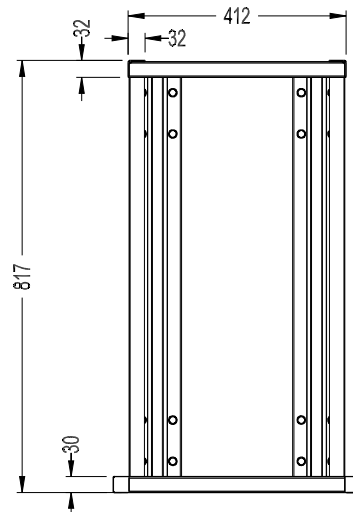
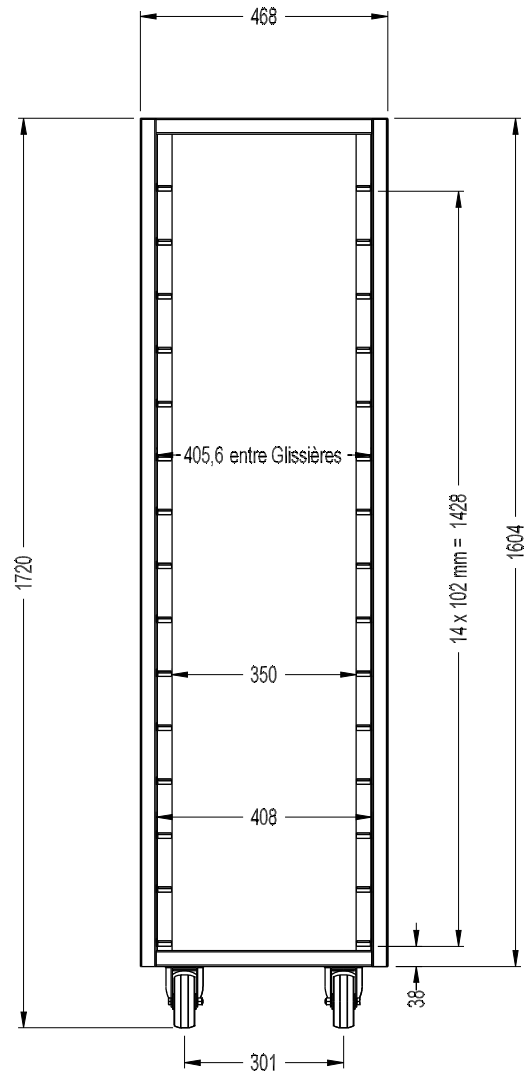
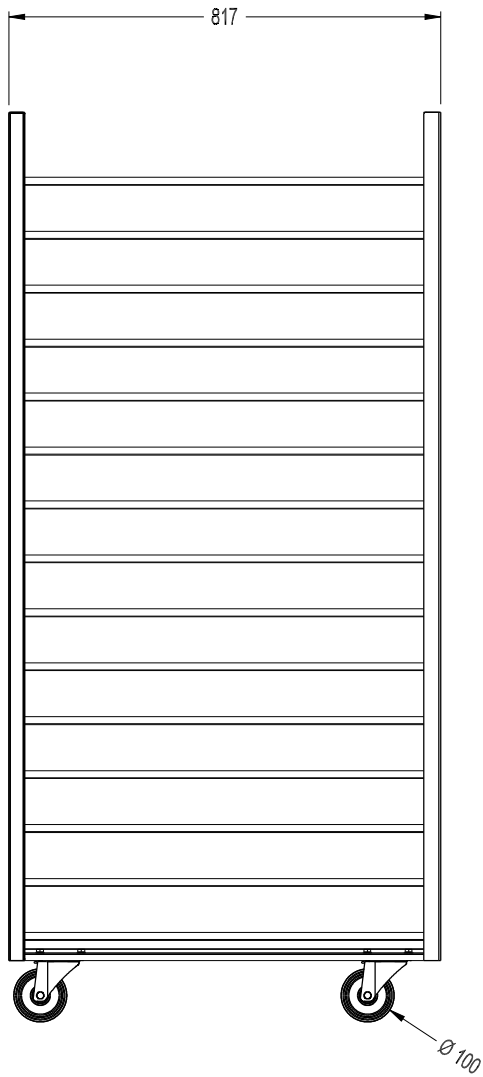

12	ROULETTE ZINGUEE HT T°C	4	Ø 100	RLTZ000022
11	ECROU H M8 A2	16	.	VISE000002
10	RONDELLE GROWER Ø8 A2	16	.	VISR000068
9	RONDELLE PLATE Ø8 A2	16	.	VISR000007
8	VIS TH M8x16 A2	16	.	VISV000014
7	EMBOUT 15/10	2	30x30	FPSTR70411
6	PROFIL DE FIXATION 20/10	2	755	FPSTR72584
5	GLISSIERE DROITE 15x29 12/10	15	812	FPSTR76263
4	GLISSIERE GAUCHE 15x29 12/10	15	812	FPSTR76264
3	CORNIERE 32x32 20/10	2	1604	FPSTR76620
2	CHAPEAU (2 TUBES) 30x30 LG 408	2	408	CHDIV12147
1	TUBE 30x30x1.2	2	1602	RPT01C3012
Repère	Designation	Nb	Dimension	Reference

< 500 mm	± 1
500 - 1000 mm	± 2
> 1000 mm	± 5
∠ // ⊥	2

ECH: 1/10	CHARIOT 15 NIVEAUX 400x800		Dessiné par: MORHAIN R.
Reference: CHBOU00321	Indice: A	26 Kg	02/10/19
Matière: ACIER INOX	Traitement: BRUT		

4

3

2

1