

INDICE	REP.	Modifications	DATE	NOM
.	.	Création	17/10/00	ER
A	.	Suppression tubes intermédiaires	13/11/00	ER
B	.	Echelle soudure électronique	27/06/03	ER

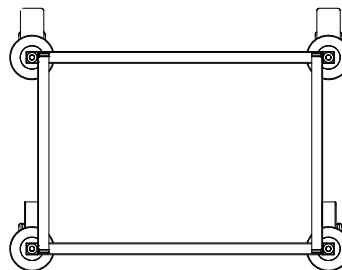
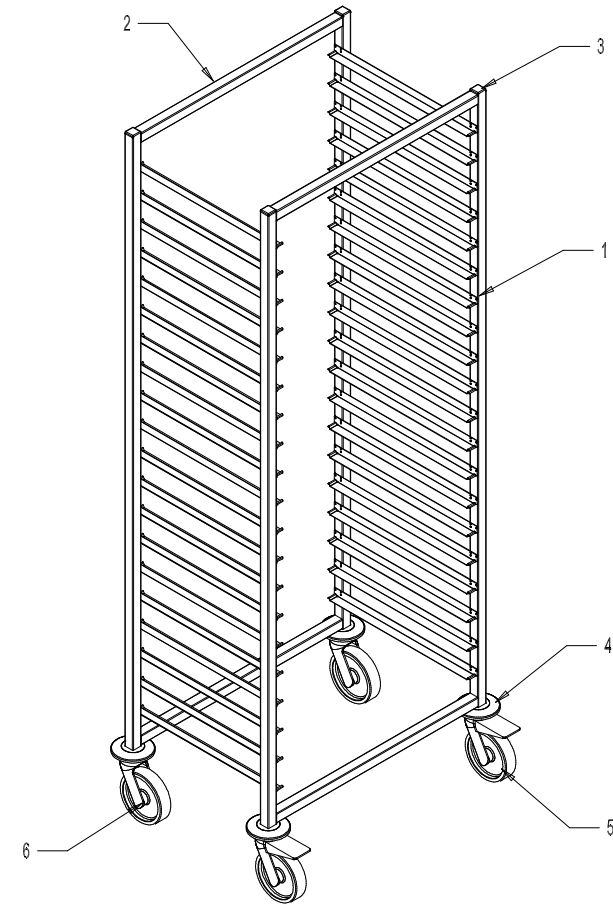
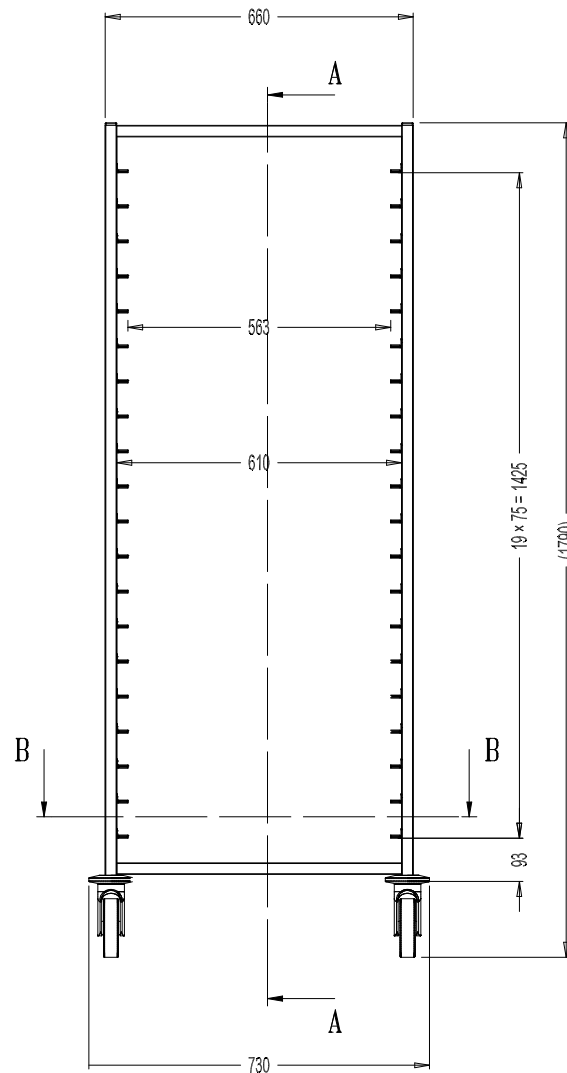
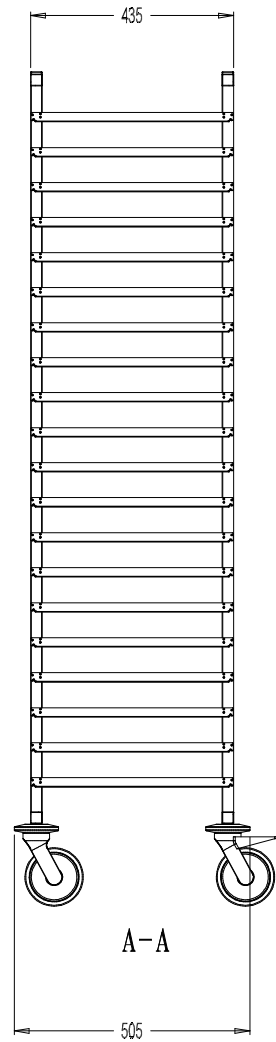

B-B

8	VIS TETE BOMBEE	4	M8*16 A2 TORX	VISV000053
7	GLISSIERE	40	20 x 23.5 x 1.2 LG 433	FPSTR71404
6	ROULETTE SANS FREIN	2	Ø125	.
5	ROULETTE AVEC FREIN	2	Ø125	.
4	BUTOIR	4	Ø95	RLTB000001
3	EMBOUT CARRE	4	25 x 25	DIV000008
2	TUBE 25x25x1.2	4	610	RPT01C2612
1	TUBE 25x25x 1.2	4	1620	RPT01C2612
Repère	Désignation	Nb	Dimension	Référence
ECH: 1/4		CHARIOT G/P - 20 NIVEAUX ENTREE 600		Dessiné par: REMI
Référence: CHGA010748		Matériau: ACIER INOX AUSTENITIQUE		Le: 01/07/04
Matériau: ACIER INOX AUSTENITIQUE		Indice: B		Traitement: BROSSAGE

< 500 mm	± 1
500 - 1000 mm	± 2
> 1000 mm	± 5
∠ // ⊥	2

