

INDICE	REP.	Modifications	DATE	NOM
A	.	CREATION	.	.

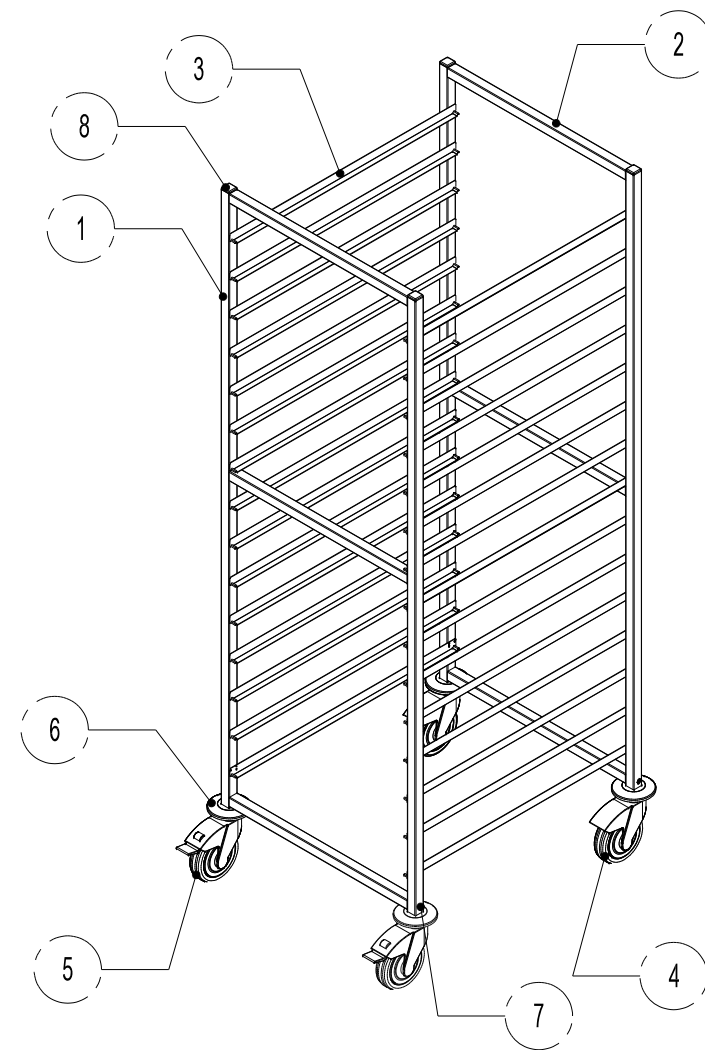

8	EMBOUT CARRE	4	25x25	DIV0000008
7	VIS TB M6x16 TORX	4		VISV0000053
6	BUTOIR	4	Ø95	RLTB0000011
5	ROULETTE AVEC FREIN	2	Ø125	RLTP0000014
4	ROULETTE SANS FREIN	2	Ø125	RLTP0000013
3	GLISSIERE 18 x 14.5 Ep: 1.2	30	683	FPSTR70878
2	TUBE 25*25*1.2	6	538	RPT01C2512
1	TUBE 25*25*1.2	4	1620	RPT01C2512
Repère	Désignation	Nb	Dimension	Référence

< 500 mm	± 1
500 - 1000 mm	± 2
> 1000 mm	± 5
□ // ⊥	2

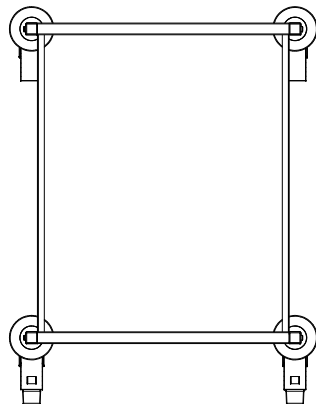
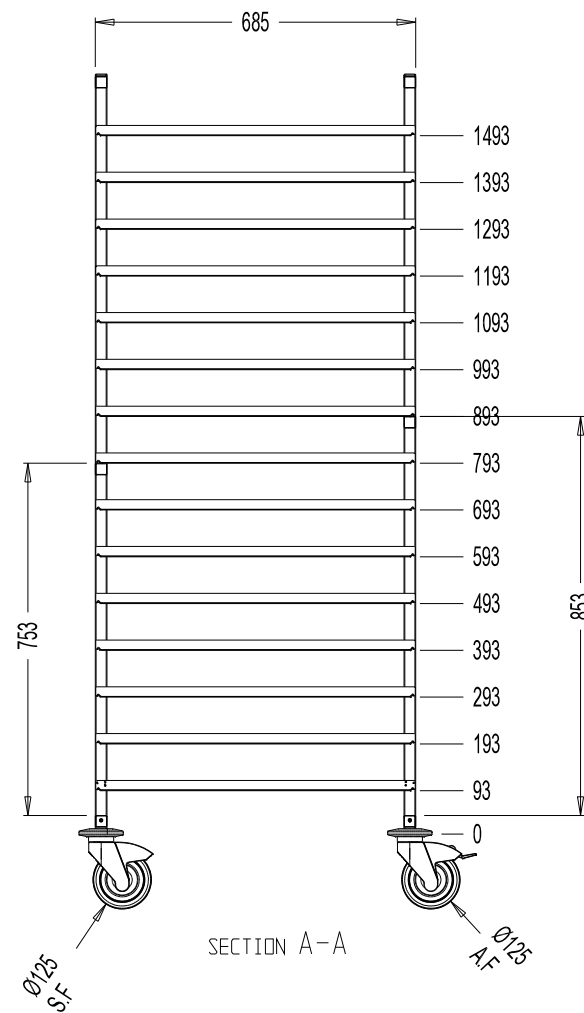
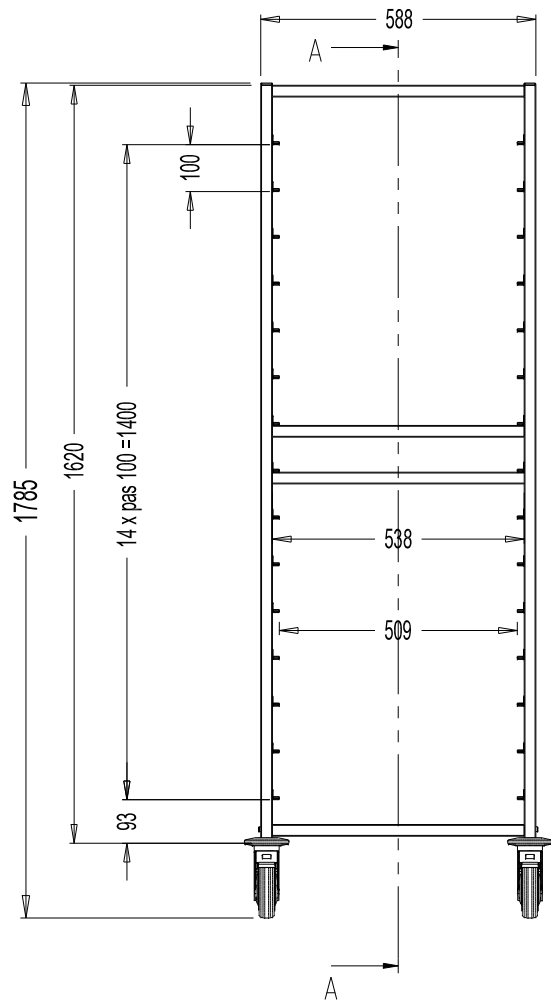

CHARIOT 2/1 HT 1785
15 NIVEAUX - PAS 100 mm

Référence : CHGA011097

Matière : ACIER INOX AUSTENITIQUE

Indice : A

Dessiné par : L. CARTELLI

Le : 12 Juillet 10

Poids théorique : 15 Kg

Traitement : BROSSAGE