

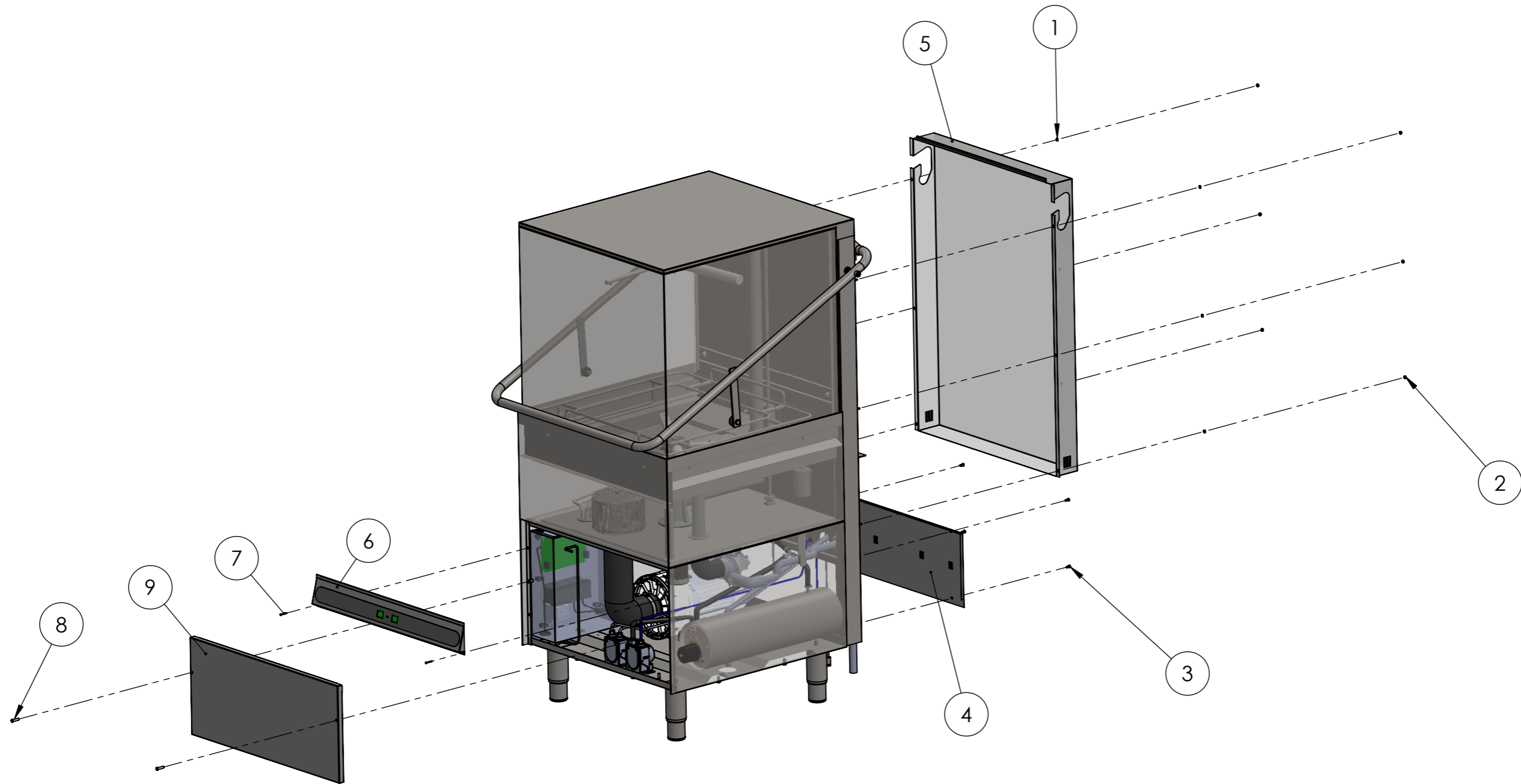

ITEM NO.	REF.	DESCRIPTION	QTE.
1	002.00.00140	RONDELLE DE SERRAGE INOX Φ 4	6
2	002.00.00095	ECROU INOX M4	6
3	003.00.00309	VIS TARAUDEUSE EN INOX Φ 4,1 X 13	4
4	001.15.00082	COUVERTURE ARRIÈRE INFÉRIEUR 1500	1
5	001.15.00001	CAPOT ARRIERE 1500	1
6	003.15.00119	PANNEAU DE CONTROL COMPLET A1510	1
7	001.00.00213	VIS INOX M4X15	2
8	001.00.00247	VIS M6X25 DIN6115	2
9	001.15.00156	CAPOT AVANT A1510	1



SERIES DESCRIPTION:
LAVE-VAISSELLE

MODEL DESCRIPTION:
1510

MODEL VERSION:
380V-415V 3~N 50/60 Hz

MODEL CODE:
004.15.00027

PAGE:
01

REVISION:
01



ITEM NO.	REF.	DESCRIPTION	QTE.
10	002.15.00044	GUIDE PLASTIQUE D.30	4
11	003.00.00346	VIS AUTOTARAUDEUSE 4,8X13	12
12	001.15.00150	CAPOT SUPERIEUR	1
13	002.15.00074	SERRE-JOINT TEFLON $\Phi 16 \times \Phi 8 \times 1$	2
14	003.00.00221	SERRE-JOINT INOX $\Phi 6 \times \Phi 18$	2
15	003.00.00323	COPLER $\Phi 8 \times \Phi 31$	2
16	002.15.00053	BOULON INOX AXE M8x35 LONG	2
17	003.00.00274	INOX BOULON M10 X 64 ALLEN	2
18	001.15.00029	POIGNÉE DE PORTE 1500	1
19	001.00.00093	M10 ECROU INOX	2
20	002.00.00095	ECROU INOX M4	4
21	002.00.00274	TEFLON 10X4X1	4
22	002.00.00117	ECROU INOX M8	2
23	002.15.00052	INOX AXE BOULON COURT M8 X 17	2

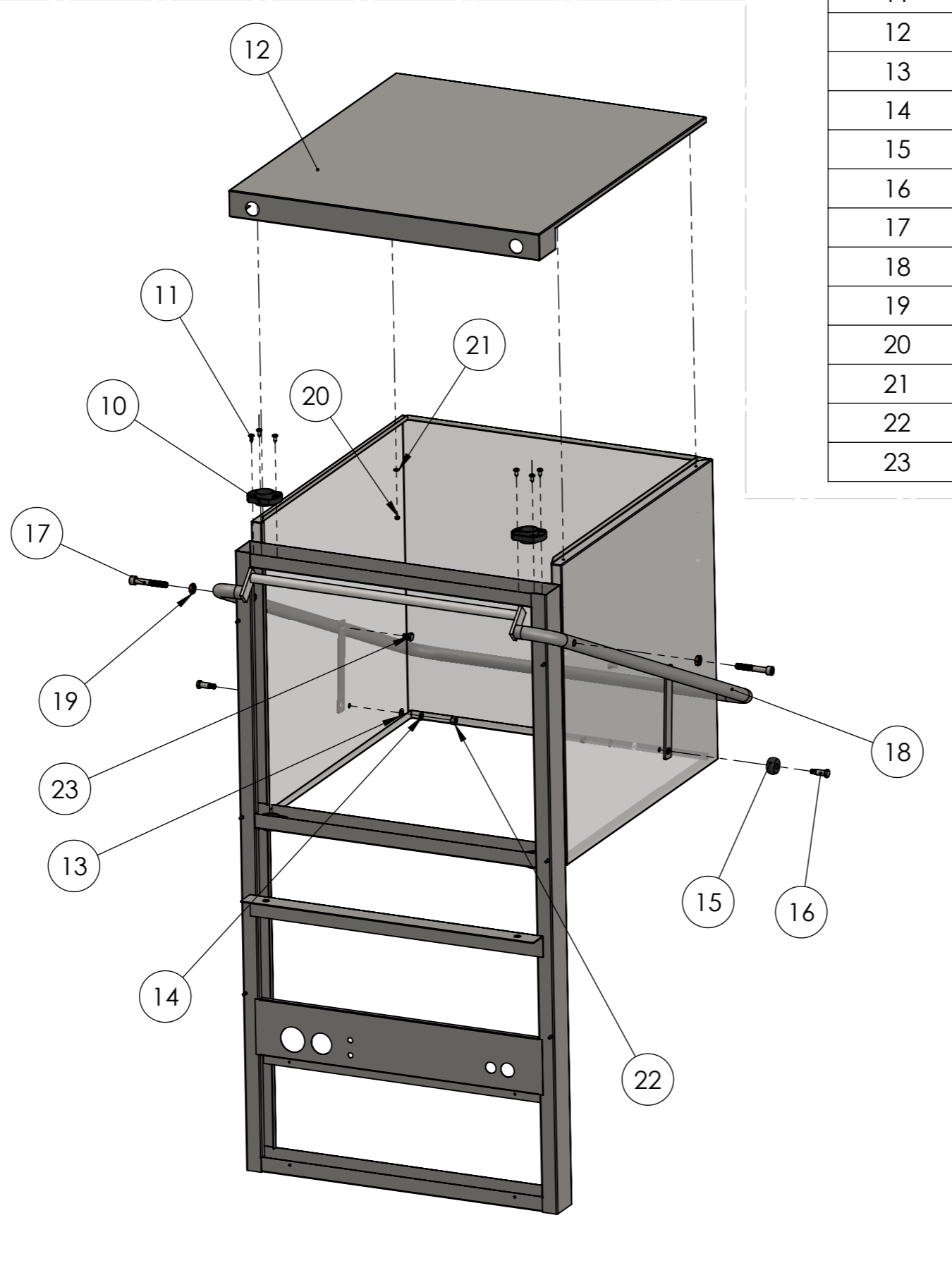

SERIES DESCRIPTION:
LAVE-VAISSELLE

MODEL DESCRIPTION:
1510

MODEL VERSION:
380V-415V 3~N 50/60 Hz

MODEL CODE:
004.15.00027

PAGE:
02

REVISION:
01

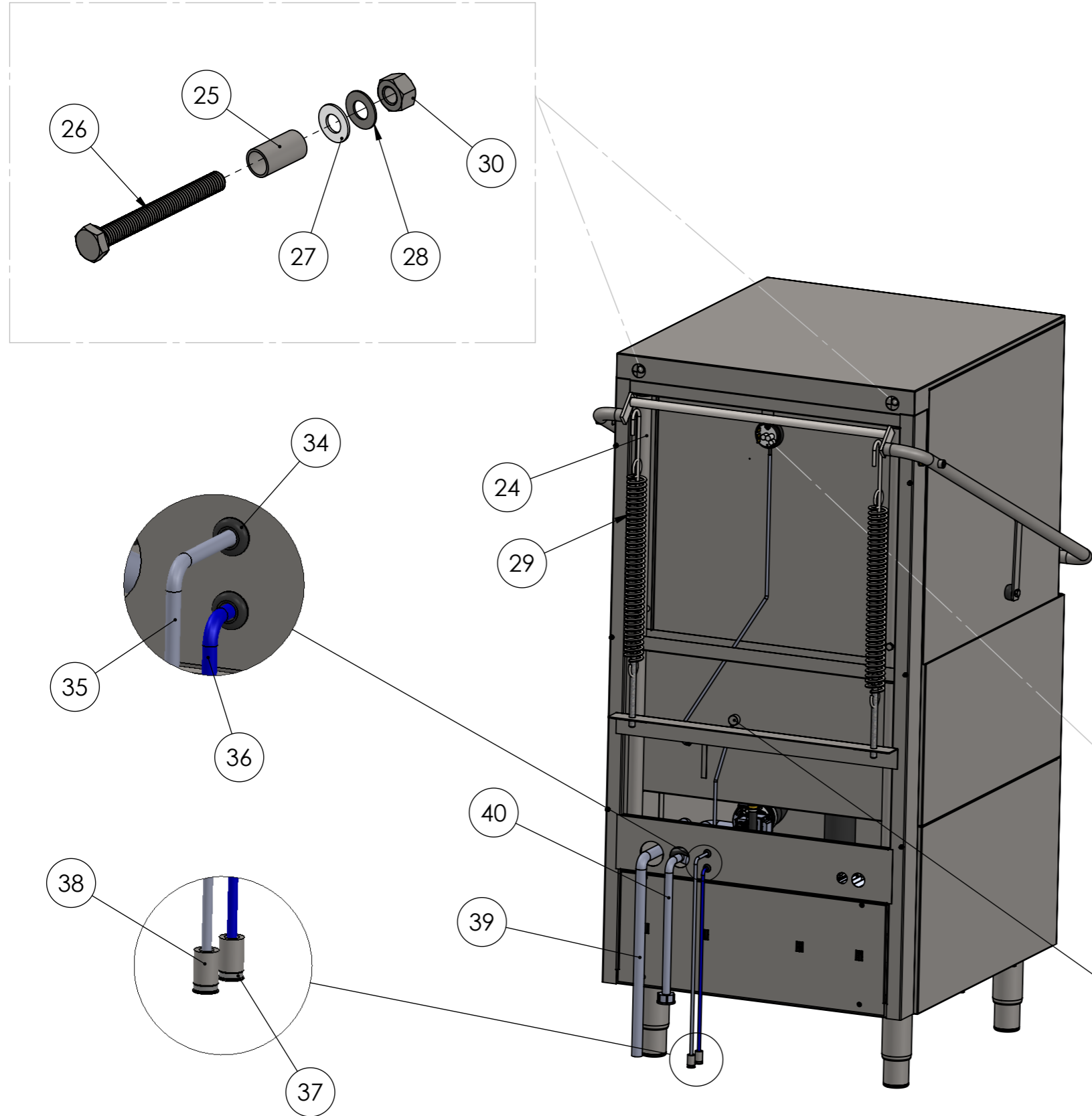

ITEM NO.	REF.	DESCRIPTION	QTE.
24	001.15.00084	TUBE DE SUPPORT DE LA HOTTE $\Phi 30 \times 1100$	2
25	001.15.00145-1	ENTRETOISE DE CAPOT EN INOX $\Phi 12 \times 24$	2
26	001.15.00036	INOX BOULON M8 X 70	2
27	002.15.00074	SERRE-JOINT TEFLON $\Phi 16 \times \Phi 8 \times 1$	2
28	003.00.00221	SERRE-JOINT INOX $\Phi 6 \times \Phi 18$	2
29	001.15.00037	RESSORT DE PORTE TURBO 1500	2
30	002.00.00117	ECROU INOX M8	2
31	002.00.00207	VIS AUTOTARAUDEUSE 4,2 X 19	1
32	002.00.00233	INJECTEUR DE RÉSERVOIR DE DÉTERGENT	1
33	003.00.00033	PRESSOSTAT	1
34	003.00.00025	PROTECTEUR DE CÂBLE EN CAOUTCHOUC	2
35	003.00.00140_11	TUBE TRANSPARENT 4x6	1
36	003.00.00487-7	TUBE PVC BLEU 4x6	1
37	002.00.00242	FILTRE EN PLASTIQUE POUR LA VANNE D'AIDE AU RINÇAGE	2
38	002.00.00195	BALANCE F15X20	2
39	002.00.00264	TUYAU D'ÉVACUATION COUDÉ OD29-ID19	1
40	002.00.00109	TUYAU D'ENTRÉE 1500mm	1

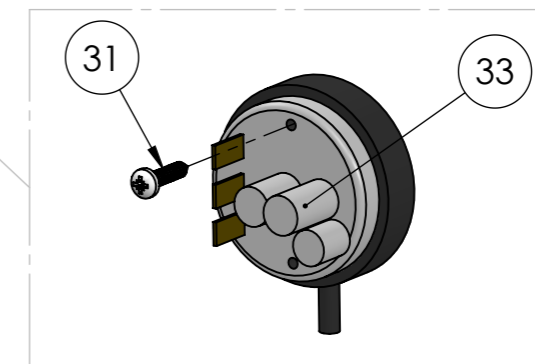

SERIES DESCRIPTION:
LAVE-VAISSELLE

MODEL DESCRIPTION:
1510

MODEL VERSION:
380V-415V 3~N 50/60 Hz

MODEL CODE:
004.15.00027

PAGE:
03

REVISION:
01



ITEM NO.	REF.	DESCRIPTION	QTE.
41	002.00.00140	RONDELLE DE SERRAGE INOX Φ4	2
42	002.00.00095	ECROU INOX M4	2
43	003.00.00473	POMPE À DÉTERGENT PÉRISTALTIQUE G300 / 230V	1
44	003.00.00658	POMPE D'AIDE AU RINÇAGE PÉRISTALTIQUE G302 / 230V	1
45	006.15.00009	BOITE ELECTRIQUE COMPLETE	1
46	003.00.00516	RONDELLE ACIER Φ6X18	3
47	001.00.00204	RONDELLE DE SERRAGE GALVANISEE LOCK 6,4x11x0,7	3
48	003.00.00041	ECROU M6 GALVANISE	3
49	003.15.00119	PANNEAU DE CONTROLE COMPLET A1510	1

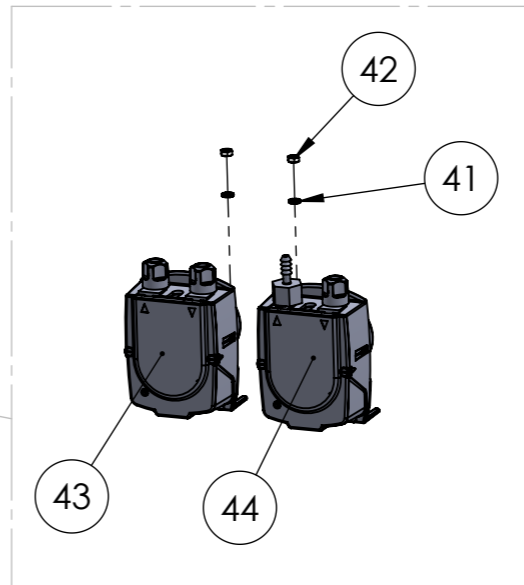
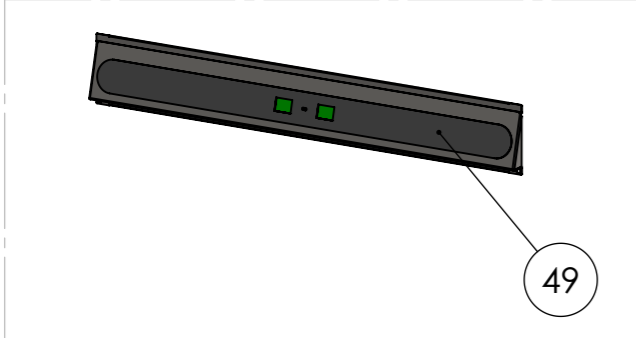
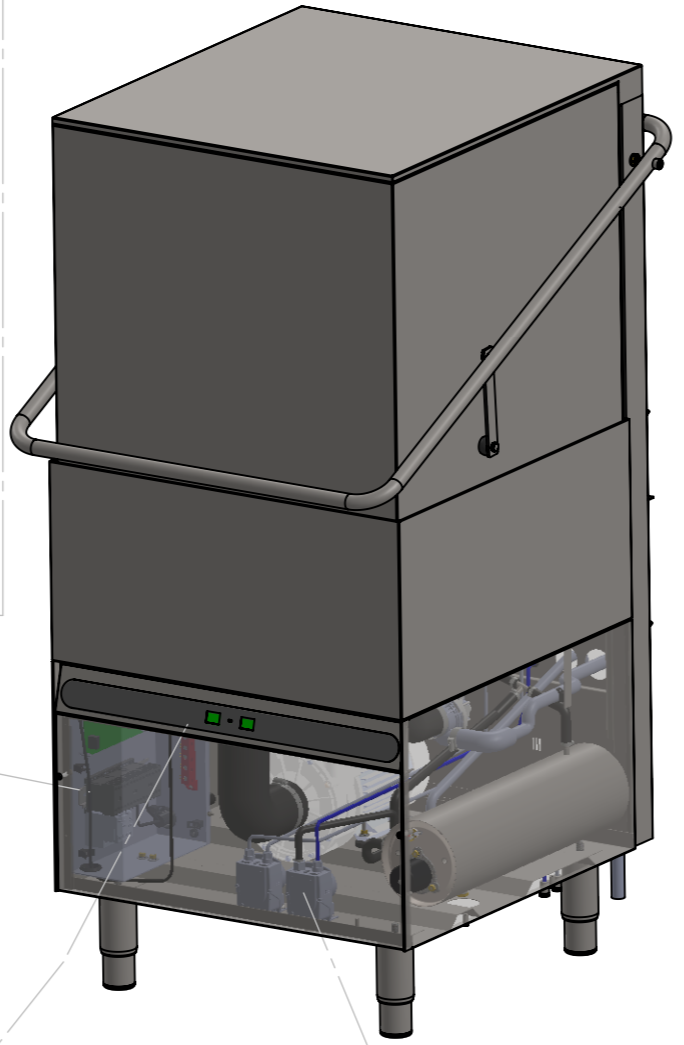
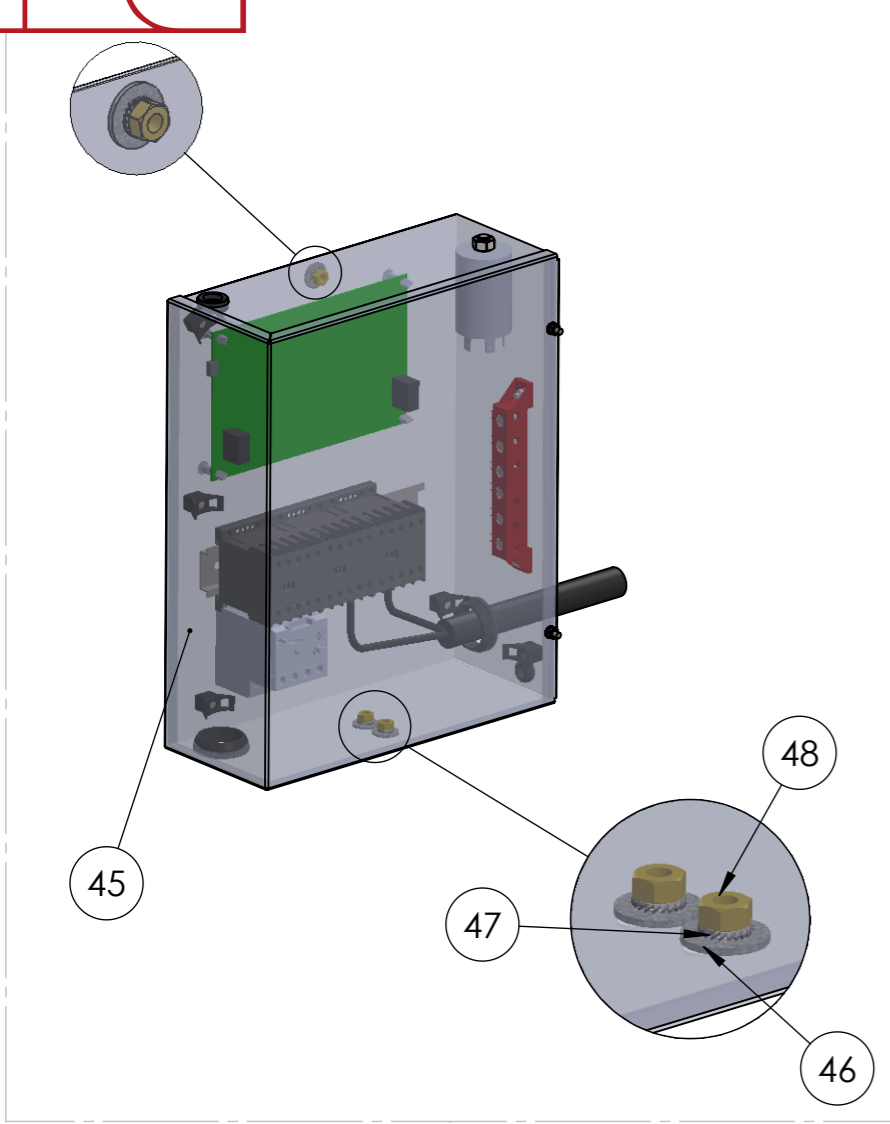

SERIES DESCRIPTION: LAVE-VAISSELLE	MODEL DESCRIPTION: 1510	MODEL VERSION: 380V-415V 3~N 50/60 Hz	MODEL CODE: 004.15.00027	PAGE: 04	REVISION: 01
--	-----------------------------------	---	------------------------------------	--------------------	------------------------



ITEM NO.	REF.	DESCRIPTION	QTE.
50	001.15.00155	PANNEAU D'AFFICHAGE INOX A1510	1
51	003.00.00609	INTERFACE UTILISATEUR 7 SEGM. VERSION AFFICHAGE	1
52	002.00.00090	GALV. ECROU M3	4
53	003.15.00117	FILM POUR A1510 (LCD)	1
54	003.00.00629	CÂBLE DE CONNEXION ATLAS- UTILISATEUR L=1000mm	1

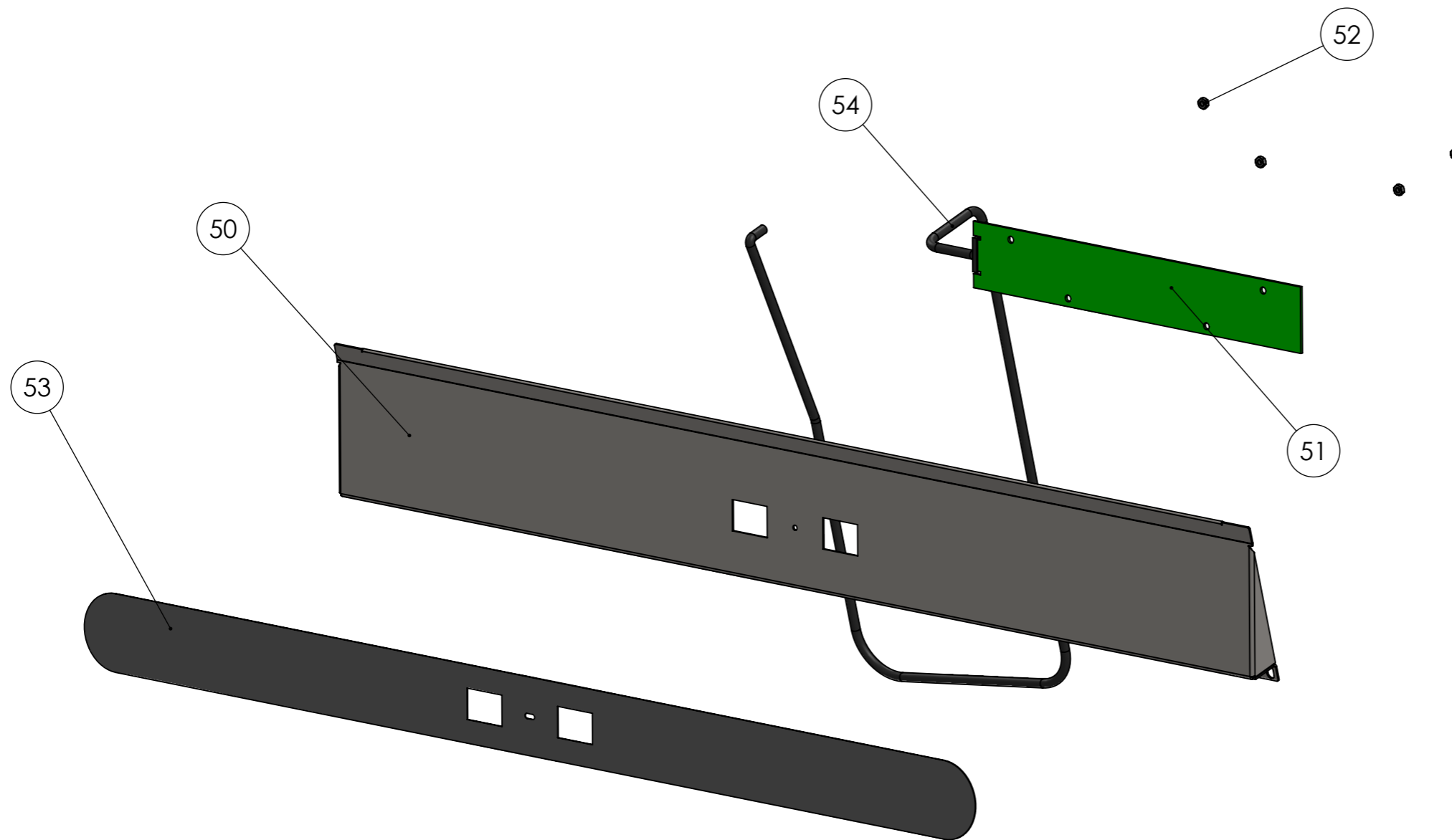

ITEM CODE:
003.15.00119

ITEM DESCRIPTION:
CONTROL PANEL COMPLETE
A1510

SERIES DESCRIPTION:
LAVE-VAISSELLE

MODEL DESCRIPTION:
1510

MODEL VERSION:
380V-415V 3~N 50/60 Hz

MODEL CODE:
004.15.00027

PAGE:
05

REVISION:
01



ITEM NO.	REF.	DESCRIPTION	QTE.
55	001.15.00101-1	PANNEAU DE COMPOSANTS ÉLECTRIQUES 1500	1
56	003.00.00056	CONTACTEUR MAGNÉTIQUE	3
57	003.00.00607	VERSION DU TABLEAU PRINCIPAL DE L'ATLAS	1
58	003.00.00630	ESPACEUR PCB RC-12 PLASTIQUE	4
59	003.15.00010	RELAIS DE SURCHARGE THERMIQUE 2,5 - 4,0	1
60	003.00.00030	TABLEAU D'ALIMENTATION ÉLECTRIQUE 6CON	1
61	003.00.00625	FILTRE ÉLECTROMAGNÉTIQUE 250V 50/60Hz 10A 40oC	1
62	003.00.00025	PROTECTEUR DE CÂBLE EN CAOUTCHOUC	1
63	003.00.00347	PROTECTION DES CÂBLES EN CAOUTCHOUCN.01	1
64	003.00.00466	PROTECTEUR EN CAOUTCHOUC POUR TUYAUX	2
65	003.00.00494	SERRE-JOINT EN PLASTIQUE	5
66	001.15.00102-1	COUVERCLE DE BOÎTE DE COMPOSANTS ÉLECTRIQUES 1500	1
67	003.00.00301	ECROU M8 GALV	1
68	003.00.00046	ECROU M4 (GALV)	4
69	002.00.00140	RONDELLE DE SERRAGE INOX Φ4	2
70	003.15.00118	ENSEMBLE DE CÂBLAGE PRINCIPAL A1510 NED	1

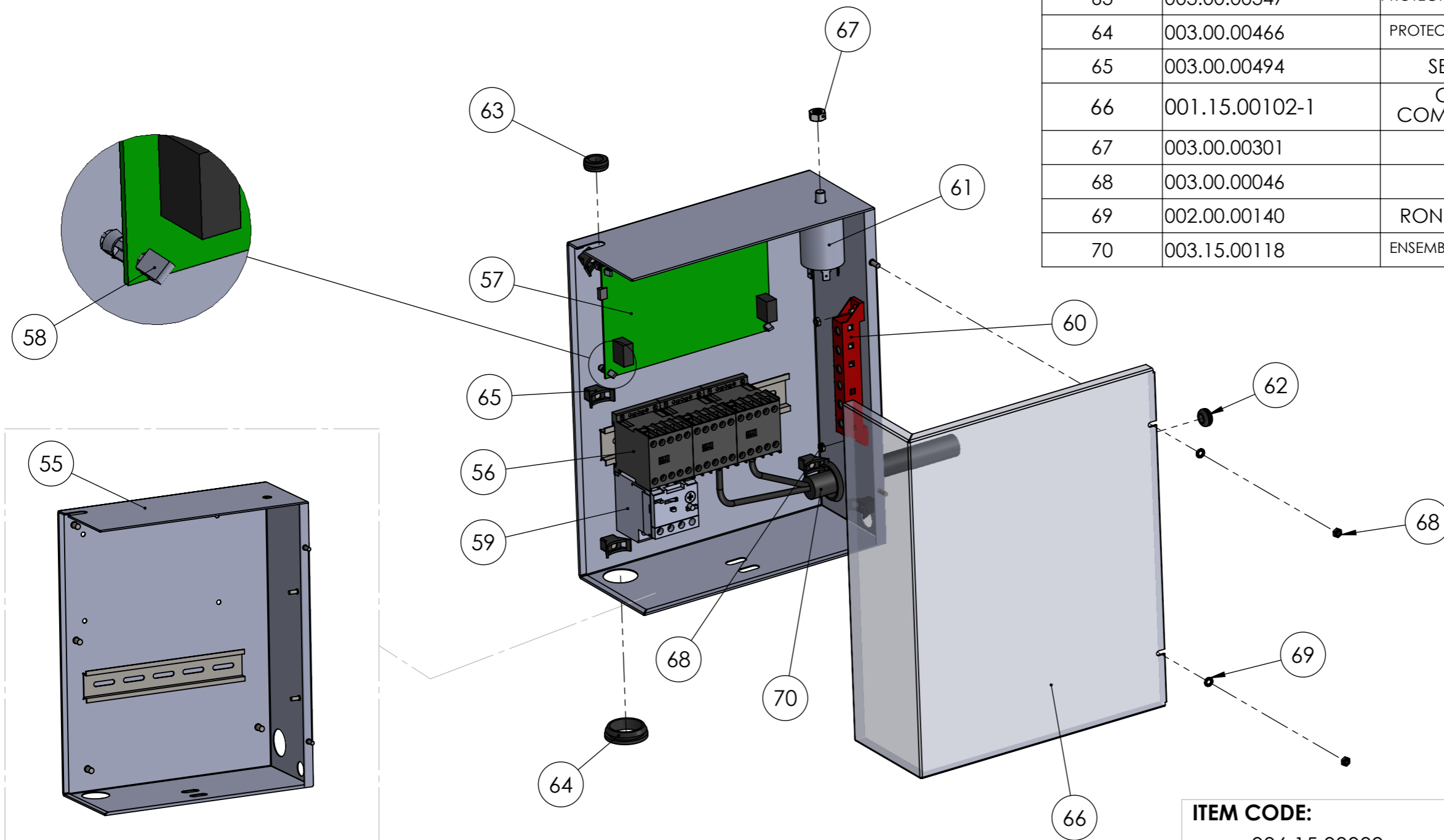

ITEM CODE:
006.15.00009

MODEL CODE:
004.15.00027

ITEM DESCRIPTION:
ELECTRICAL BOX COMPLETE

PAGE:
06

REVISION:
01

SERIES DESCRIPTION:
LAVE-VAISSELLE

MODEL DESCRIPTION:
1510

MODEL VERSION:
380V-415V 3~N 50/60 Hz



ITEM NO.	REF.	DESCRIPTION	QTE.
71	003.00.00516	RONDELLE ACIER $\Phi 6 \times 18$	6
72	001.00.00204	RONDELLE SERRAGE GALVANISE $6,4 \times 11 \times 0,7$	6
73	003.00.00041	ECROU M6 GALVANISE	6
74	003.00.00063	POMPE 1,50Hp, 400V, 50Hz	1
75	002.15.00058	TUYAU D'ENTRÉE DE LA POMPE	1
76	003.00.00323-B	RONDELLE CUIVRE $\Phi 8 - \Phi 31$	4
77	002.00.00051	SERRE-JOINT 60-80	2
78	002.00.00051-1	SERRE-JOINT 60-80	2
79	002.15.00029	TUYAU DE SORTIE DE LA POMPE	1
80	006.15.00008	SURCHAUFFEUR 1500 400V COMPLET (1 ELEMENT CHAUFFANT)	1

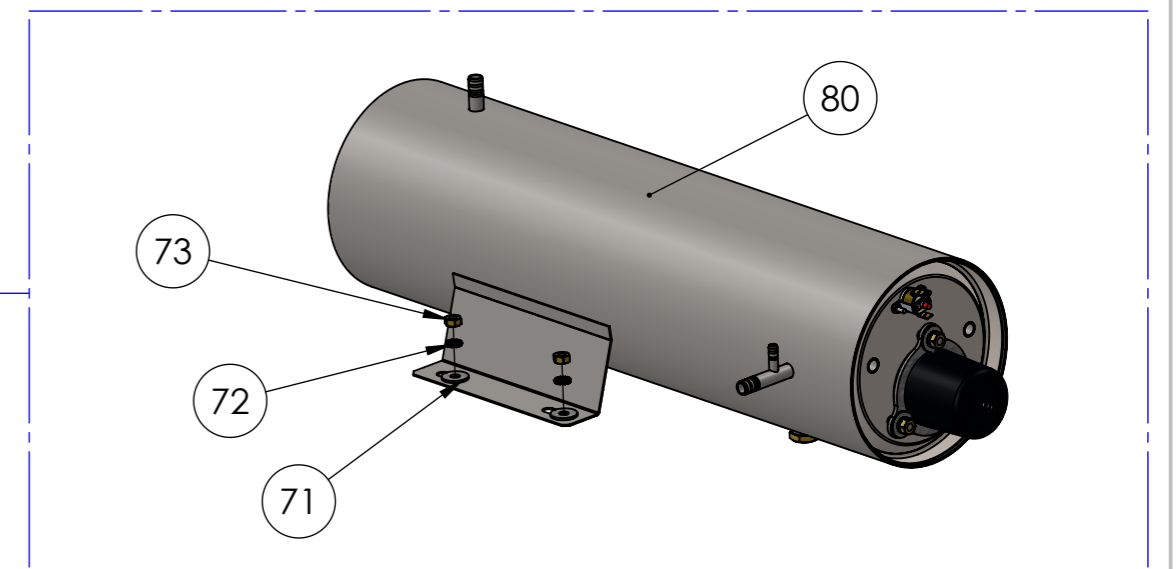
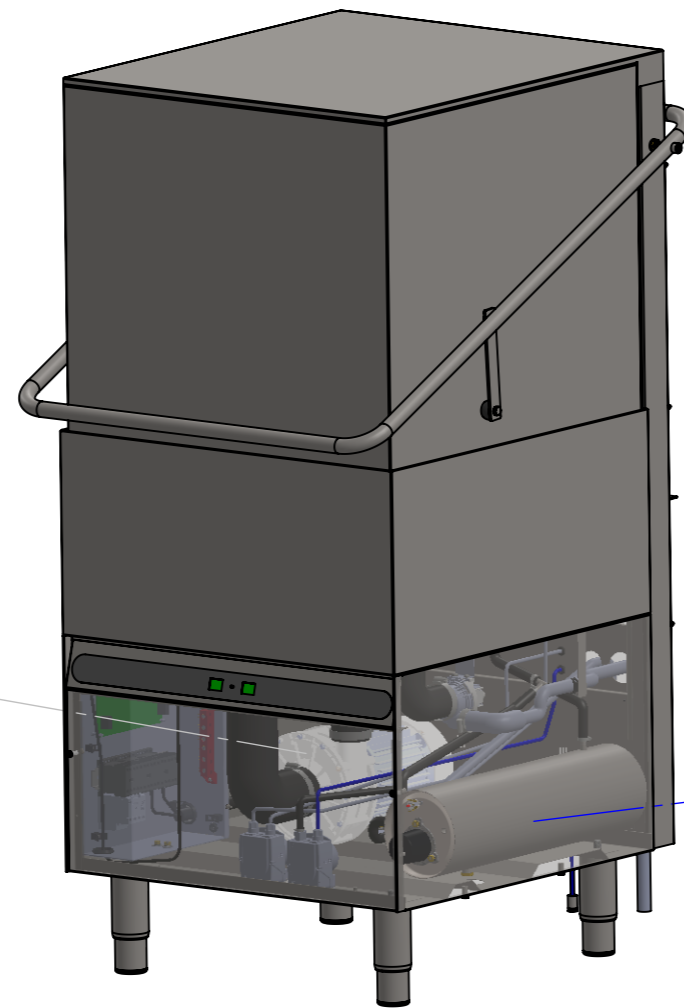
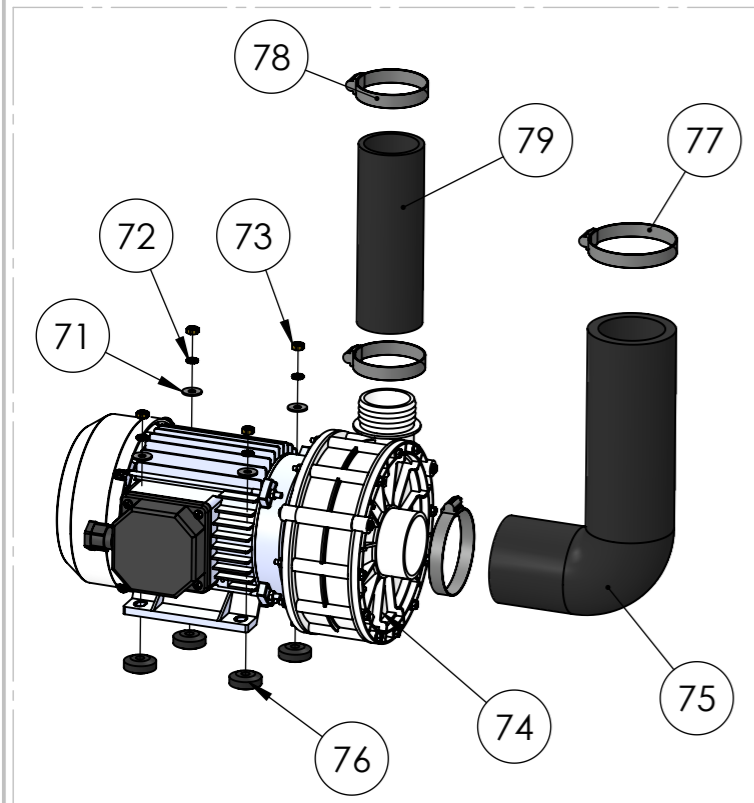

SERIES DESCRIPTION:
LAVE-VAISSELLE

MODEL DESCRIPTION:
1510

MODEL VERSION:
380V-415V 3~N 50/60 Hz

MODEL CODE:
004.15.00027

PAGE:
07

REVISION:
01

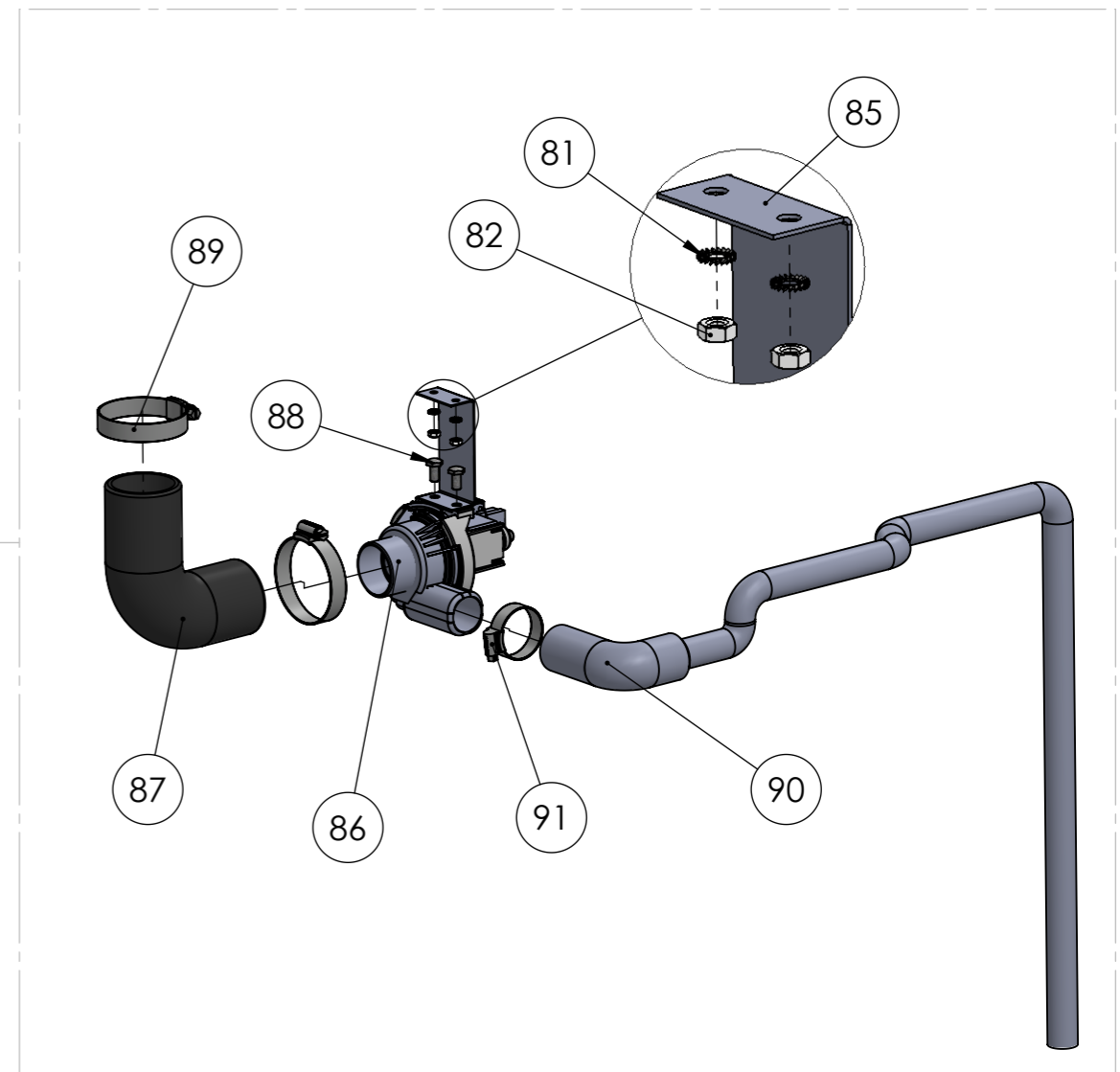
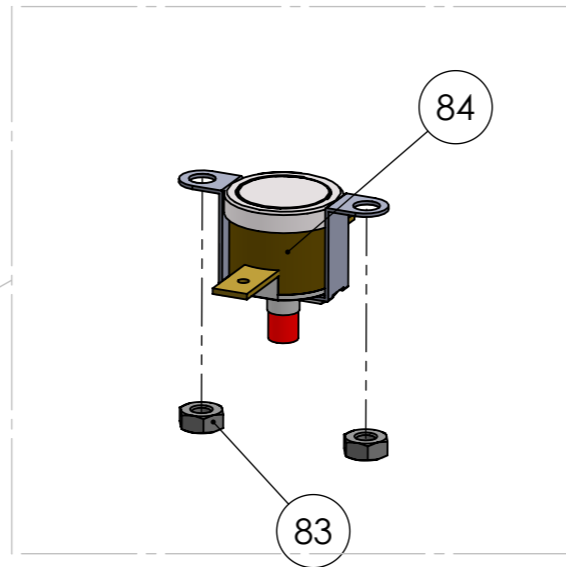
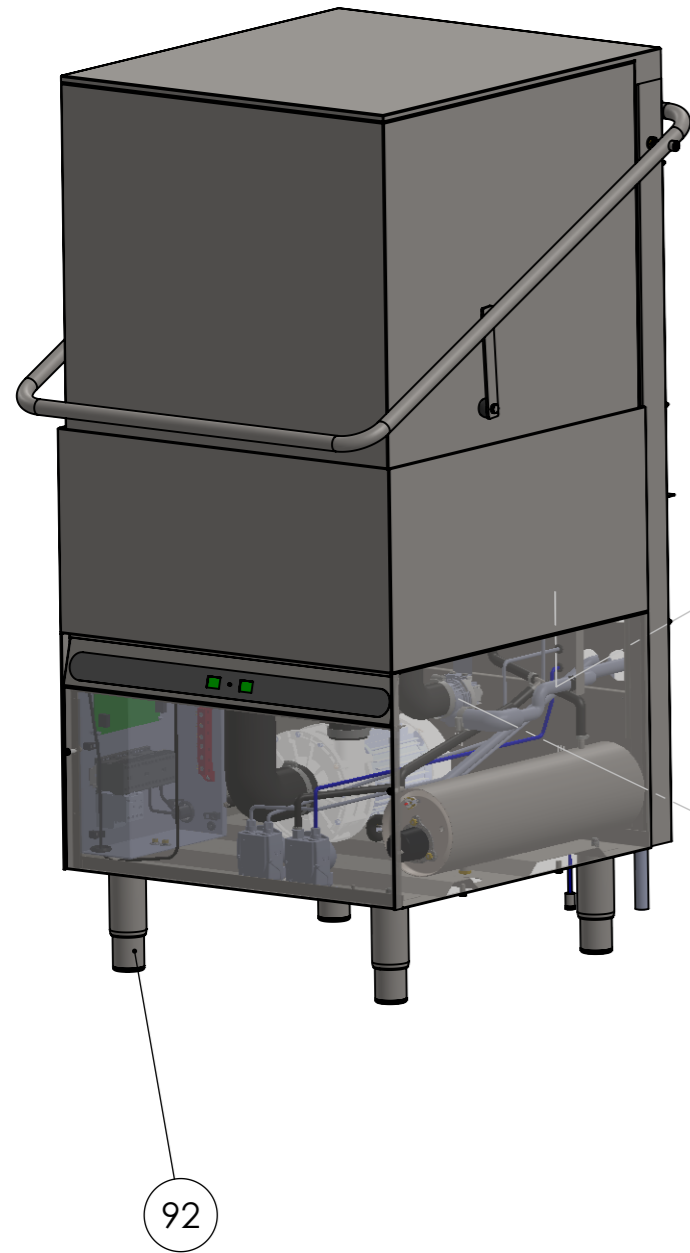

ITEM NO.	REF.	DESCRIPTION	QTE.
81	002.00.00140	RONDELLE DE SERRAGE INOX Ø4	2
82	002.00.00095	ECROU INOX M4	2
83	002.00.00090	ECROU GALV. M3	2
84	003.00.00168	RÉSERVOIR THERMOFUSIBLE 90C	1
85	001.15.00169	SUPPORT DE LA POMPE DE VIDANGE A1510	1
86	003.00.00184_595	POMPE DE VIDANGE DE RÉSERVOIR 230V / 65W	1
87	002.00.00127-1	TUYAU DE LA POMPE DE LAVAGE (ENTRÉE)	1
88	003.00.00355	VIS HEXA INOX M6X12	2
89	002.00.00049	SERRE-JOINT 35-50	2
90	002.00.00264	TUYAU D'ÉVACUATION COUDÉ OD29-ID19	1
91	003.00.00244	SERRE-JOINT 20-32	1
92	001.00.00256	PIED VERIN 1 3/4	4

SERIES DESCRIPTION:
LAVE-VAISSELLE

MODEL DESCRIPTION:
1510

MODEL VERSION:
380V-415V 3~N 50/60 Hz

MODEL CODE:
004.15.00027

PAGE:
08

REVISION:
01



ITEM NO.	REF.	DESCRIPTION	QTE.
93	003.00.00278	GALV. BOULON M4X10	2
94	003.00.00046	ECROU M4 (GALV)	2
95	003.15.00003	COMMUTATEUR DE PORTE 1500	1
96	003.00.00151	Valve d'entrée d'eau double	1

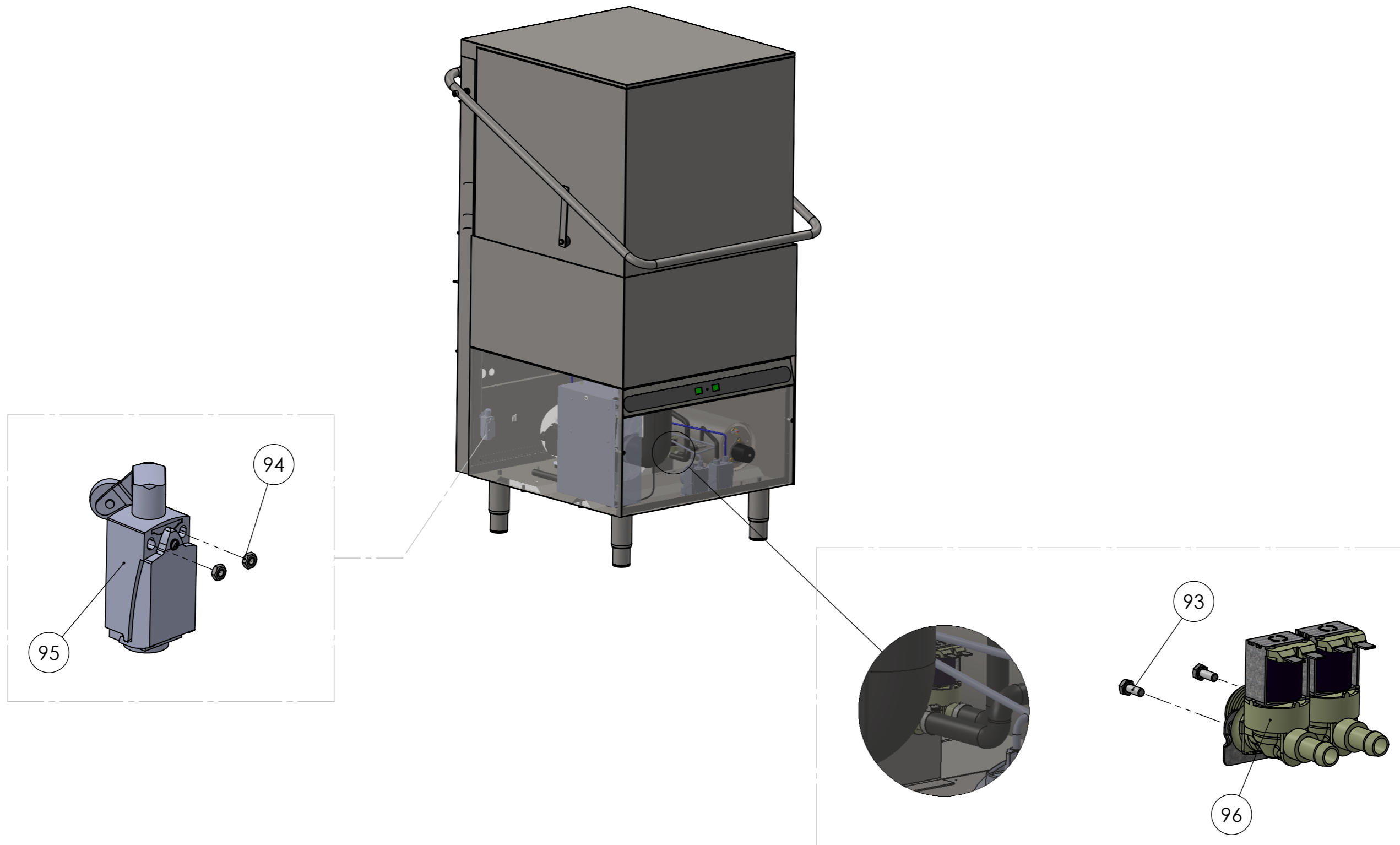

SERIES DESCRIPTION:
LAVE-VAISSELLE

MODEL DESCRIPTION:
1510

MODEL VERSION:
380V-415V 3~N 50/60 Hz

MODEL CODE:
004.15.00027

PAGE:
09

REVISION:
01



ITEM NO.	REF.	DESCRIPTION	QTE.
97	001.15.00148	SURCHAUFFEUR TURBO 1500	1
98	003.00.00575	ELEMENT CHAUFFANT SURCHAUFFEUR 1500, 7,5kW	1
99	003.00.00260	BASE DE MONTAGE DES ÉLÉMENTS DE SURCHAUFFEUR	1
100	003.00.00180	THERMOFUSIBLE DE SURCHAUFFEUR 105°C	1
101	002.00.00090	ECROU GALV. M3	2
102	002.00.00076	BOUCHON FILETÉ DE VIDANGE DE SURCHAUFFEUR	1
103	003.00.00516	RONDELLE ACIER $\Phi 6 \times 18$	3
104	001.00.00204	RONDELLE DE SERRAGE GALVANISE 6,4x11x0,7	3
105	003.00.00041	ECROU M6 GALVANISE	3
106	003.00.00004	COUVERCLE DE L'ÉLÉMENT CHAUFFANT	1

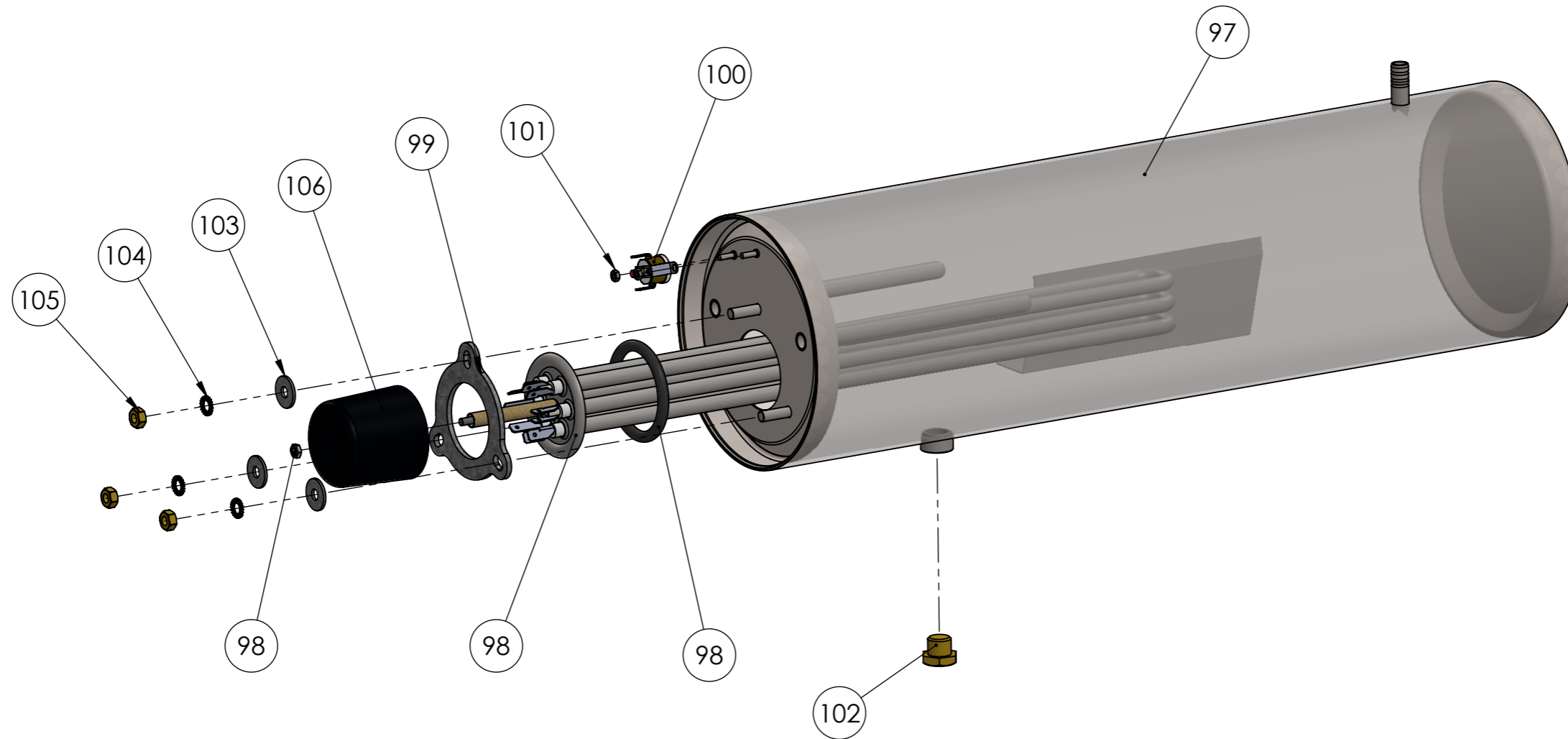

ITEM CODE:

006.15.00008

ITEM DESCRIPTION:

SURCHAUFFEUR 1500 400V COMPLET
(1 ELEMENT CHAUFFANT)

SERIES DESCRIPTION:

LAVE-VAISSELLE

MODEL DESCRIPTION:

1510

MODEL VERSION:

380V-415V 3~N 50/60 Hz

MODEL CODE:

004.15.00027

PAGE:

10

REVISION:

01

ITEM NO.	REF.	DESCRIPTION	QTE.
107	003.00.00441	BOULON HEX INOX M4 X 60	2
108	002.00.00140	RONDELLE SERRAGE INOX Φ4	2
109	002.00.00095	ECROU INOX M4	2
110	002.00.00207	VIS AUTOTARAUDEUSE 4,2 X 19	1
111	002.00.00030	RACCORD 1/2 INOX	1
112	002.00.00083	BASE DE RINÇAGE TUR - KN	1
113	002.00.00097	JOINT 20X4	1
114	002.15.00090	FOURNITURE DE RINÇAGE INOX TURBO 1500	1
115	002.00.00144	ECROU MAINTIEN DE LA CONDUITE DE RINÇAGE	3
116	002.00.00062	ECROU 1/2	1
117	001.00.00110	ECROU DOME CAP M6	4
118	002.00.00091	JOINT 3X10,5	3
119	002.15.00080	ARRIVEE D'EAU INOX TURBO 1500	1

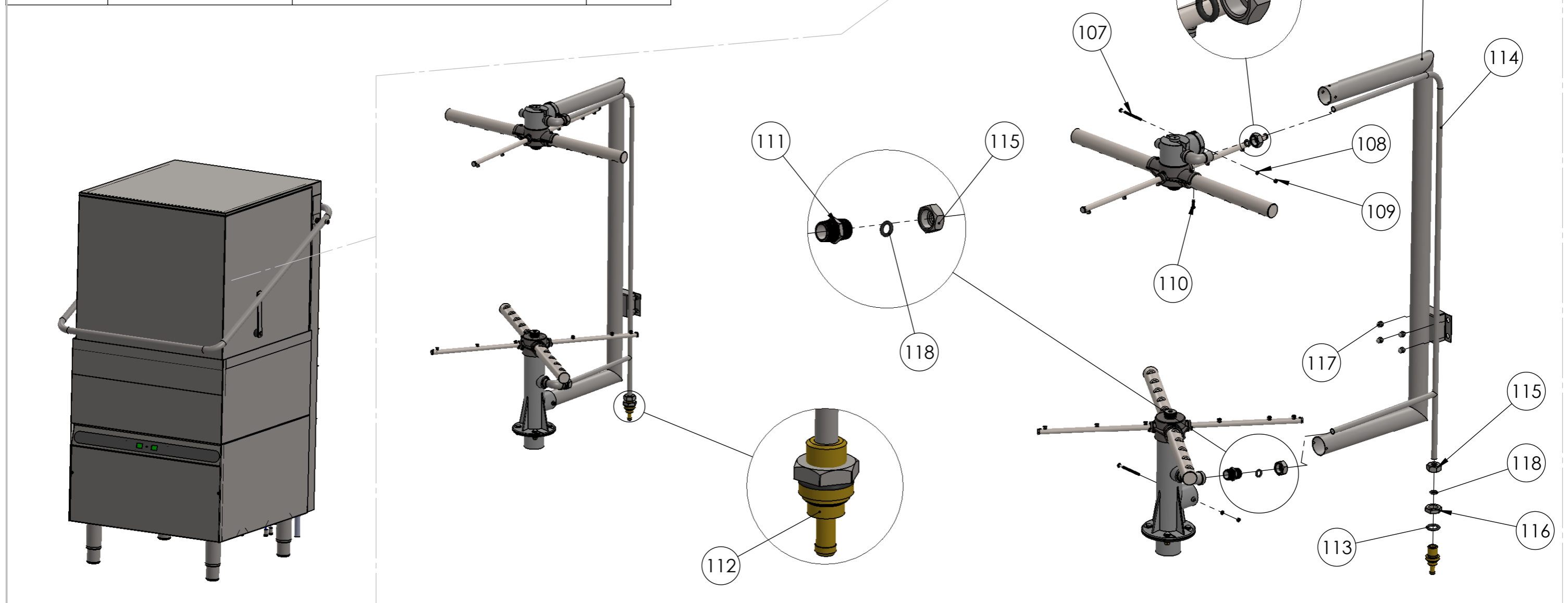

SERIES DESCRIPTION:
LAVE-VAISSELLE

MODEL DESCRIPTION:
1510

MODEL VERSION:
380V-415V 3~N 50/60 Hz

MODEL CODE:
004.15.00027

PAGE:
11

REVISION:
01



ITEM NO.	REF.	DESCRIPTION	QTE.
120	002.15.00086	LAVÈR - RINCER LA BASE SUPÉRIEURE TURBO 1500	1
121	002.15.00082	INOX AXE Ø20 M8 TURBO 1500 EVO	1
122	002.15.00091	LAVAGE ET RINÇAGE DU TURBO CROISÉ COMPLET	1
123	002.15.00083	ECROU DE RETIEN INOX Ø25 X 7 M8	1
124	002.00.00226	ANGLE EN POUCES HOMME - FEMME 1/2	1

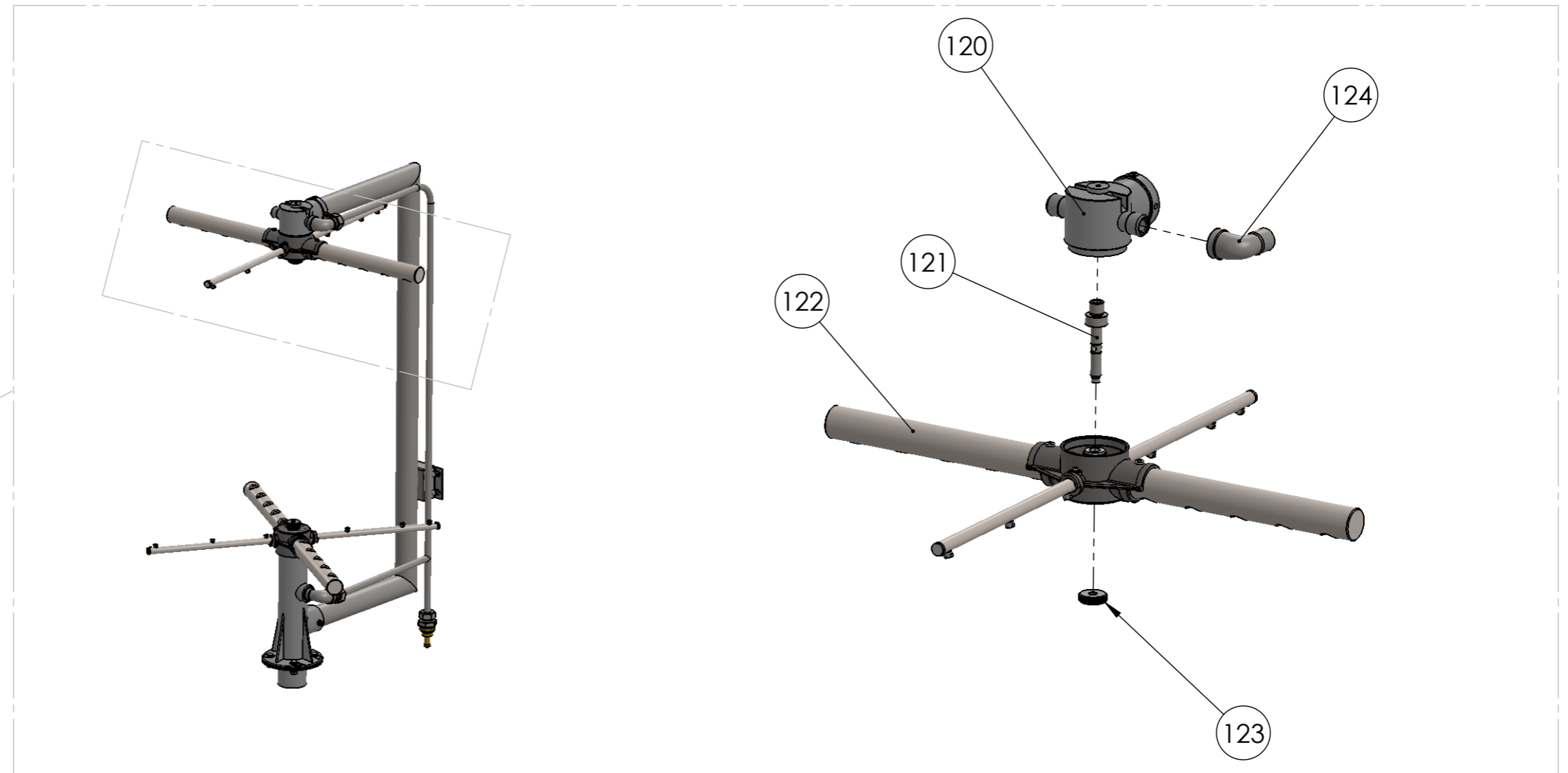
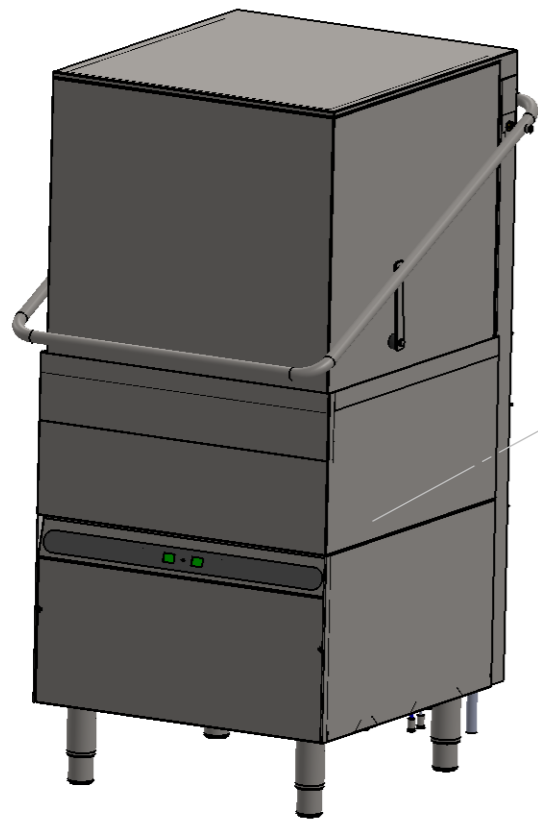

SERIES DESCRIPTION:
LAVE-VAISSELLE

MODEL DESCRIPTION:
1510

MODEL VERSION:
380V-415V 3~N 50/60 Hz

MODEL CODE:
004.15.00027

PAGE:
12

REVISION:
01

ITEM NO.	REF.	DESCRIPTION	QTE.
125	002.00.00223	JOINT D'ÉTANCHÉITÉ EN CAOUTCHOUC Φ 109X54X3	1
126	002.15.00084-1	BASE DE LAVAGE ET DE RINÇAGE TURBO 1500	1
127	002.00.00169	TEFLON 12-6-2	4
128	003.00.00104	BOULON INOX HEX M6X20	4
129	003.00.00516	RONDELLE ACIER Φ 6X18	4
130	001.00.00204	RONDELLE DE SERRAGE GALVANIZÉE 6,4x11x0,7	4
131	003.00.00041	ECROU M6 GALVANISÉ	4
132	002.15.00103	TURBO À DISQUE DE CONTRÔLE DE DÉBIT 1500	1
133	002.15.00082	INOX AXE Φ 20 M8 TURBO 1500 EVO	1
134	002.15.00091	LAVAGE ET RINÇAGE DU TURBO CROISÉ COMPLET	1
135	002.15.00083	ECROU DE RETIEN INOX Φ 25 X 7 M8	1
136	002.00.00226	ANGLE EN POUCES HOMME - FEMME 1/2	1
137	002.15.00024	PLAQUE DE RETENUE POUR LE SOCLE 1500	1

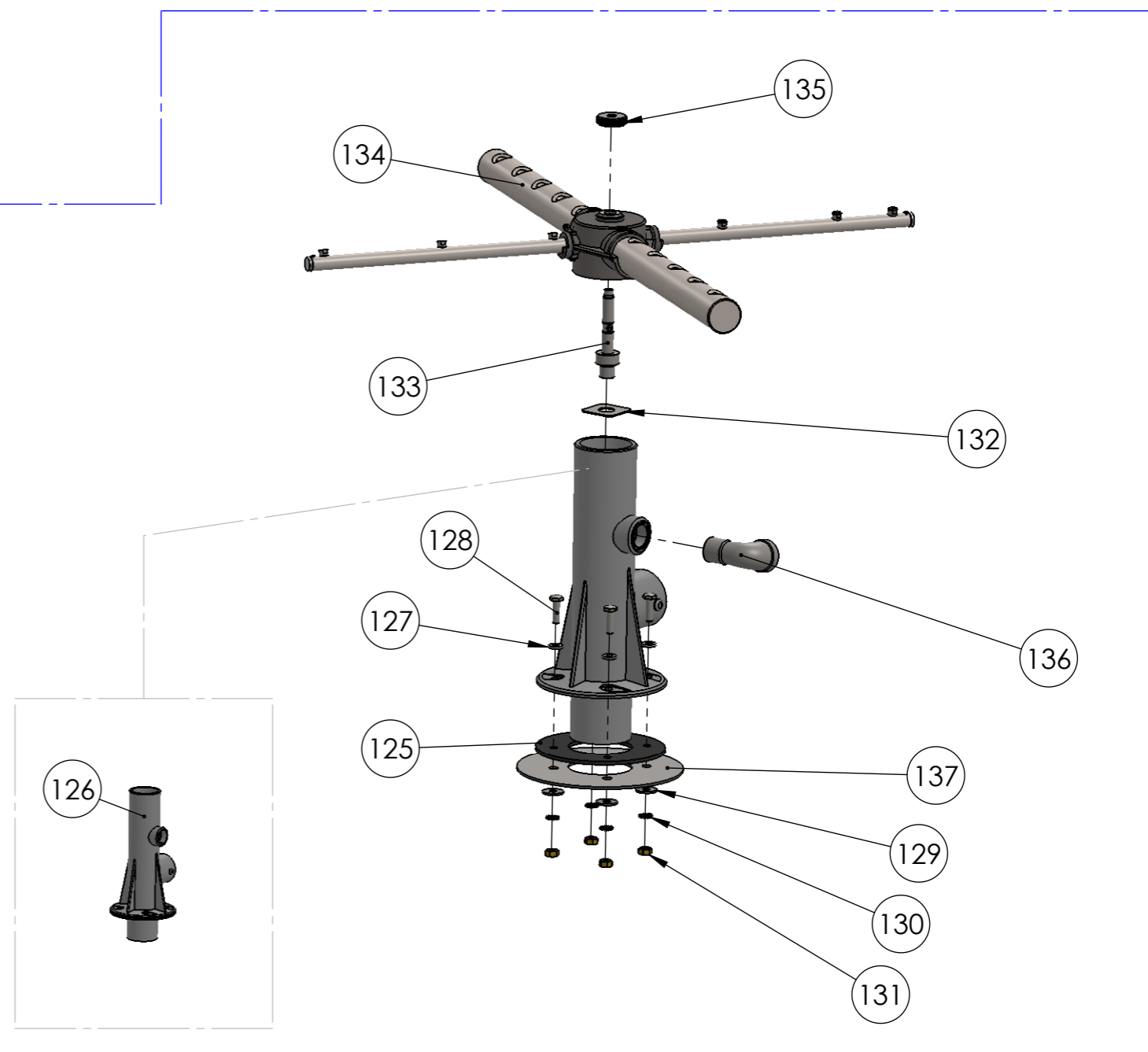
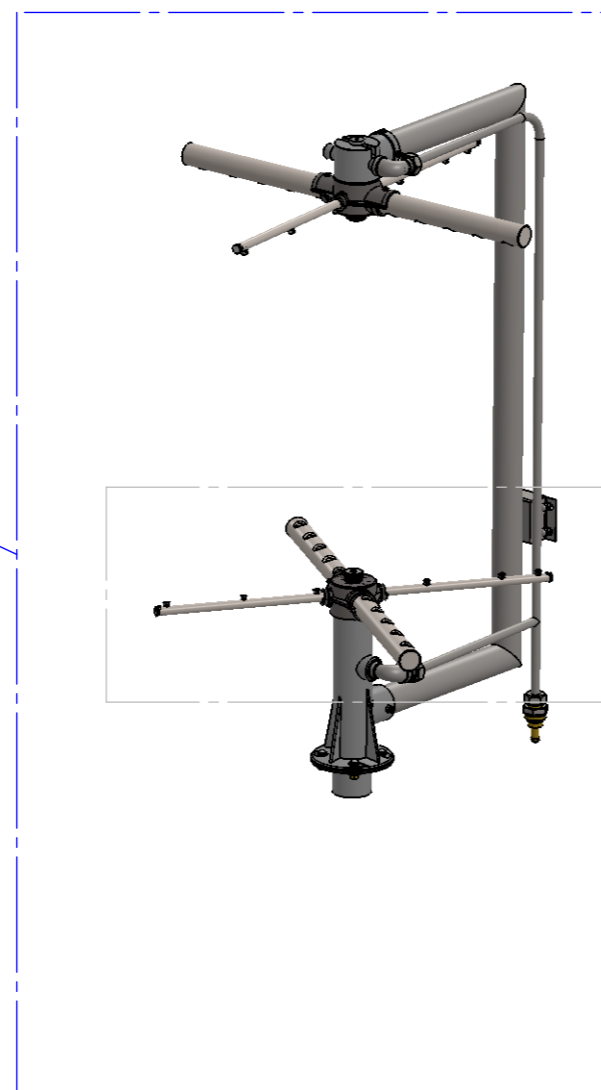
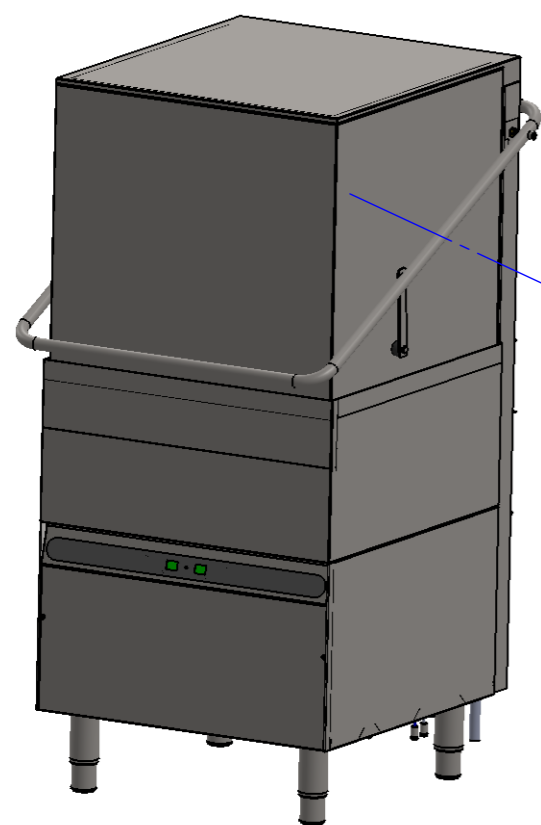

ITEM NO.	REF.	DESCRIPTION	QTE.
138	002.15.00085	CROIX RINCAGE - LAVAGE TURBO 1500	1
139	002.15.00089	TUYAUX TURBO 1500 INOX Φ 30 X 1 X 248	2
140	002.15.00093-B	TUYAU RINCAGE INOX TURBO 1500 Φ 12 X 245	1
141	002.15.00093-A	TUYAU RINCAGE INOX TURBO 1500 Φ 12 X 245	1
142	002.35.00026	TEFLON Φ 18 X 10	2
143	002.11.00008	PULVÉRISATEUR POUR BRAS DE RINÇAGE BL,EU,VE,KN,1500	6
144	002.00.00145	CAP POUR BRAS DE RINCAGE VE-KN-1500	2
145	003.00.00377	VIS INOX 3,5 X 13	2
146	003.00.00579	VIS INOX M4 X 10	2
147	003.00.00580	VIS INOX M4 X 10	2
148	001.00.00073	VIS INOX 2,9 X 10	2

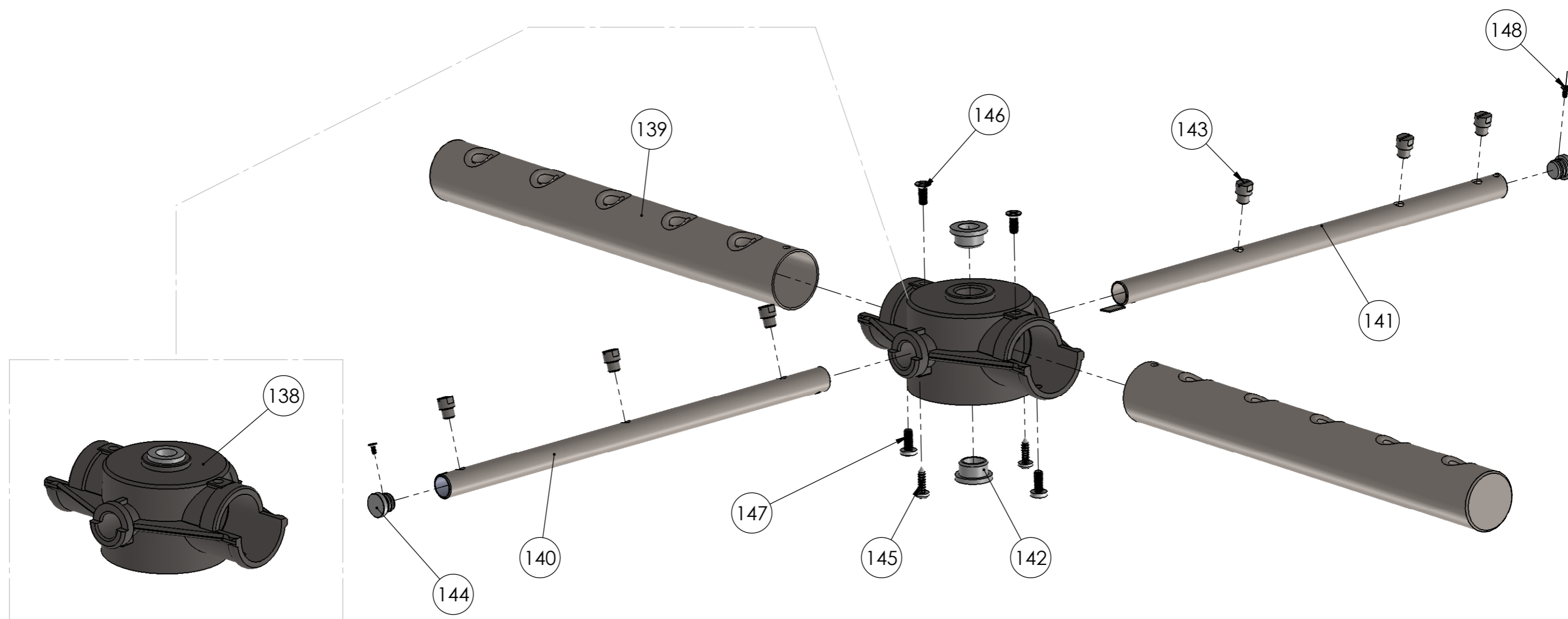

SERIES DESCRIPTION:
LAVE-VAISSELLE

MODEL DESCRIPTION:
1510

MODEL VERSION:
380V-415V 3~N 50/60 Hz

MODEL CODE:
004.15.00027

PAGE:
14

REVISION:
01



ITEM NO.	REF.	DESCRIPTION	QTE.
149	001.15.00095	SUPPORT POUR FILTRE ARRIERE	1
150	001.15.00012	ELEMENT FILTRANT	4
151	001.15.00153	Bouton en Inox pour filtre de réservoir carré 1500-600	1
152	003.00.00242	VIS INOX HEX M6X12	1
153	001.00.00110	ECROU DOME CAP M6	6
154	001.15.00113	SUPPORT PANIER 1500	1
155	001.15.00094	SUPPORT POUR FILTRE MID	1

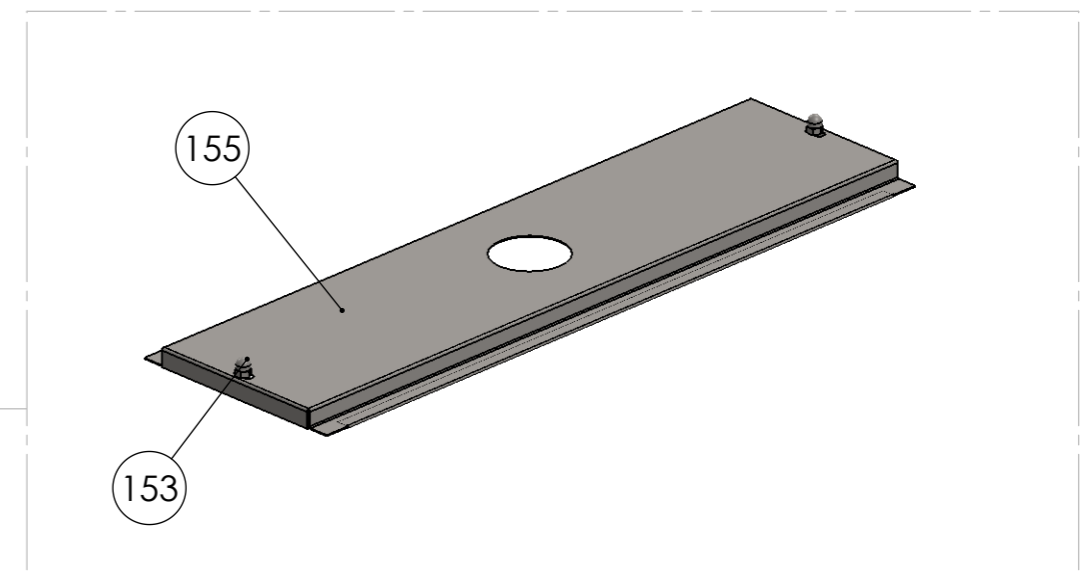
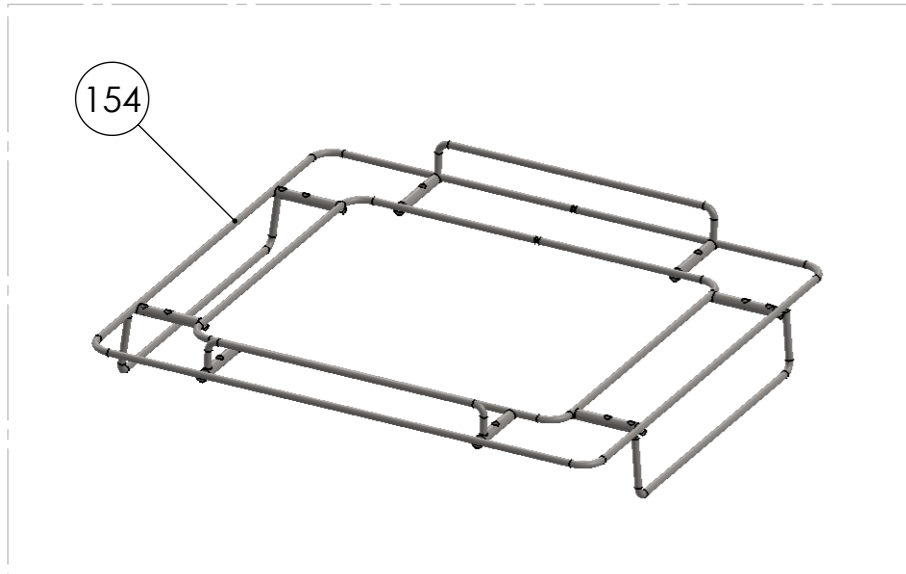
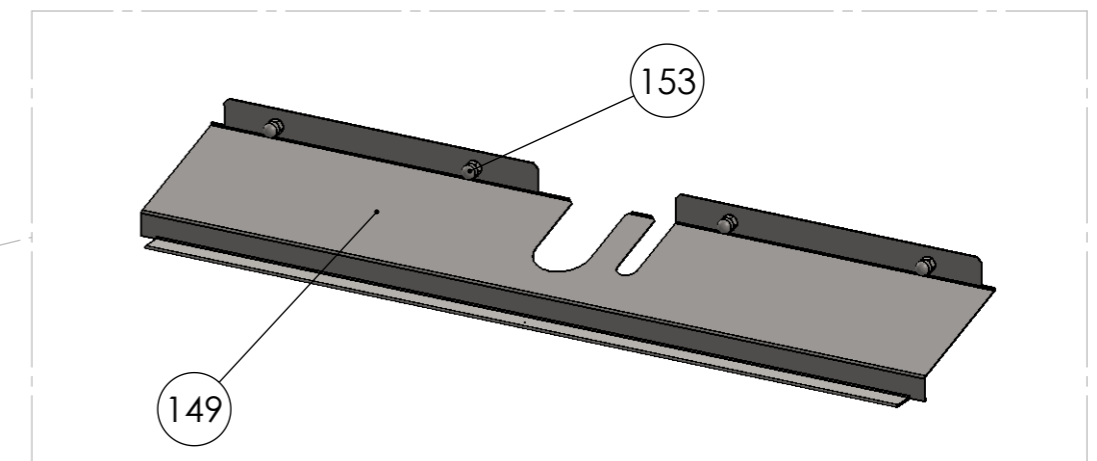
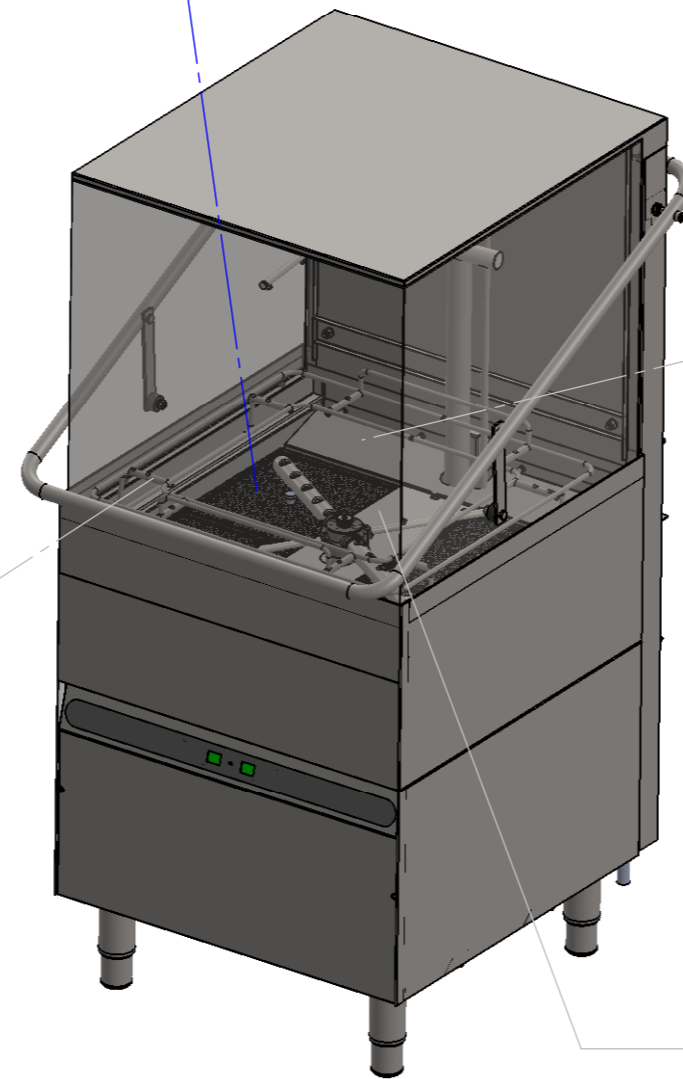
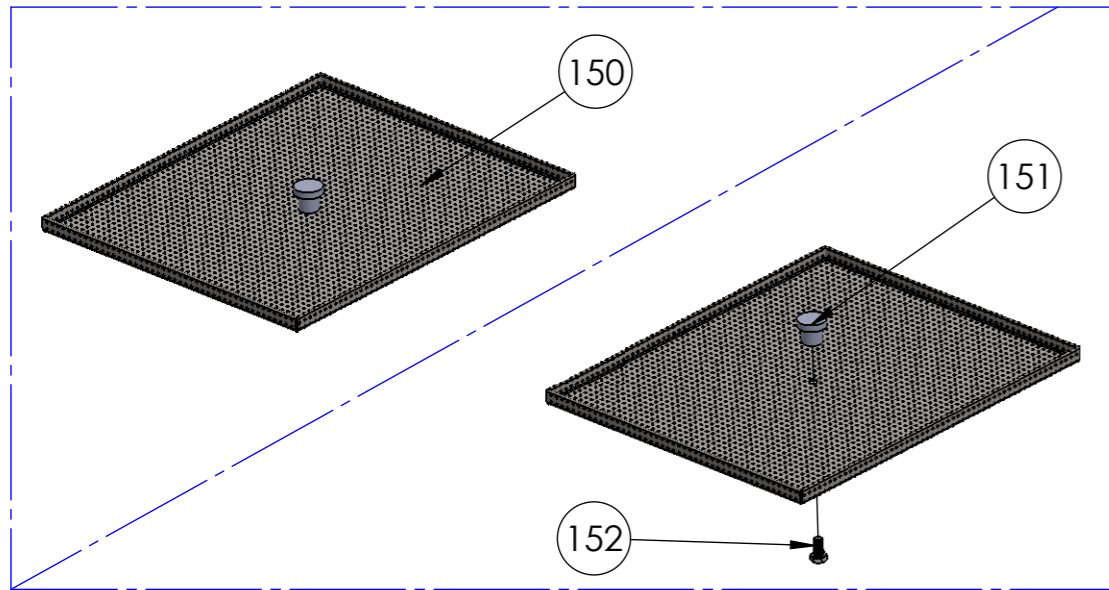

SERIES DESCRIPTION:
LAVE-VAISSELLE

MODEL DESCRIPTION:
1510

MODEL VERSION:
380V-415V 3~N 50/60 Hz

MODEL CODE:
004.15.00027

PAGE:
15

REVISION:
01

ITEM NO.	REF.	DESCRIPTION	QTE.
156	002.00.00169	TEFLON 12-6-2	4
157	003.00.00104	INOX HEX BOULON M6X20	4
158	003.00.00516	RONDELLE ACIER Ø6X18	4
159	001.00.00204	RONDELLE SERRAGE GALVANISEE 6,4x11x0,7	4
160	003.00.00041	ECROU M6 GALVANISE	4
161	002.15.00012	BASE POUR FILTRE DE RÉSERVOIR TURBO 1500	1
162	002.15.00025	PLAQUE DE RETENUE POUR LE FILTRE 1500	1
163	002.15.00075	BASE DU FILTRE DU RÉSERVOIR JOINT EN CAOUTCHOUC TURBO1500	1
164	001.15.00078	POMPE FILTRE TURBO 1500	1
165	001.00.00017	ECROU FILTRE RETIENT	1
166	003.00.00046	ECROU M4 (GALV)	1
167	003.15.00095	ÉLÉMENT DE CHAUFFAGE DE LA CUVE	1
168	002.00.00150	JOINT 45X6	1
169	003.00.00570	SUPPORT DE FIXATION DE L'ÉLÉMENT CHAUFFANT DE LA CUVE	1
170	003.00.00004	COUVERCLE DE L'ÉLÉMENT CHAUFFANT	1
171	003.00.00086	TIGE FILETÉE M4X60	1

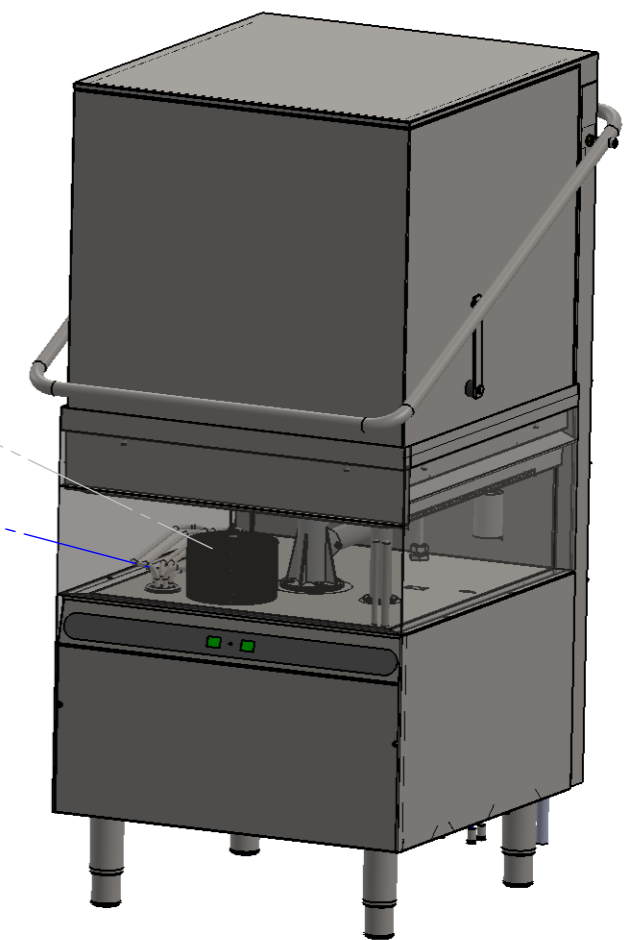
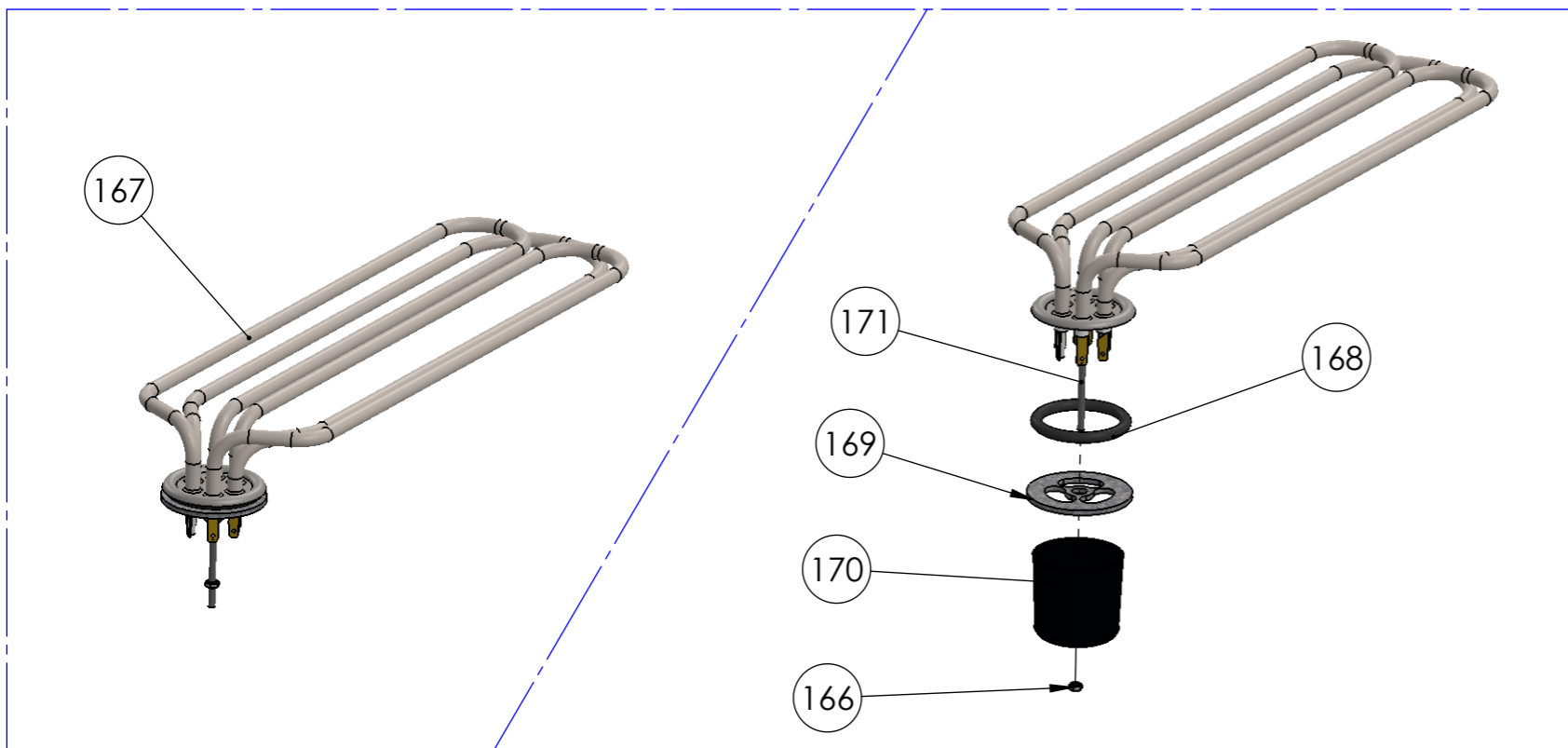
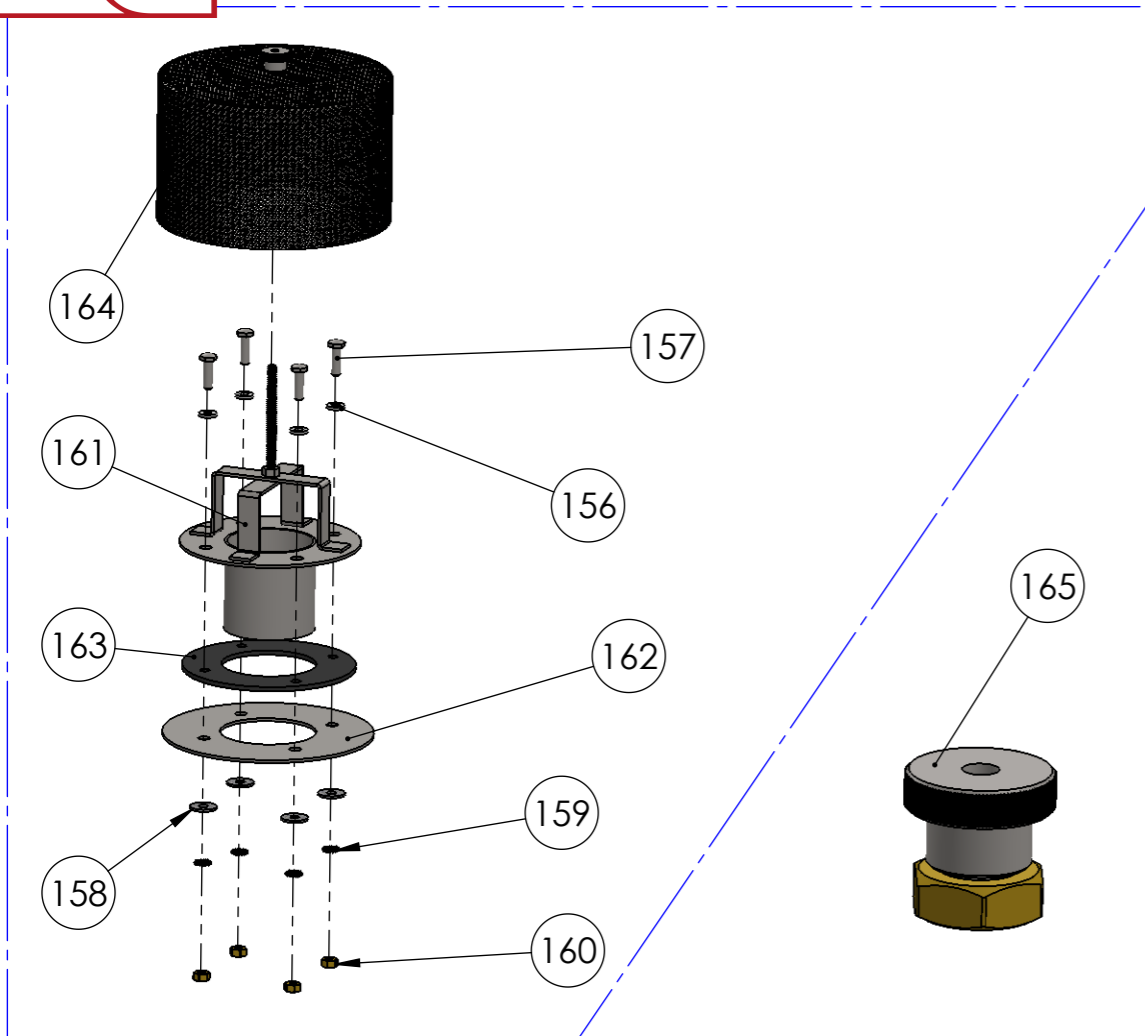

ITEM NO.	REF.	DESCRIPTION	QTE.
172	003.00.00014	CHAMBRE PRESSOSTAT	1
173	002.00.00087	ECROU M10	1
174	002.00.00091	JOINT 3X10,5	1
175	002.15.00031	TUYAU DE VIDANGE ET DE TROP-PLEIN	1
176	002.15.00017	BASE DE DRAINAGE ET DE DÉBORDEMENT	1
177	002.00.00102-1	JOINT DE FOND DE VIDANGE 1500	1
178	002.00.00037	ECROU 1 1/2"	1

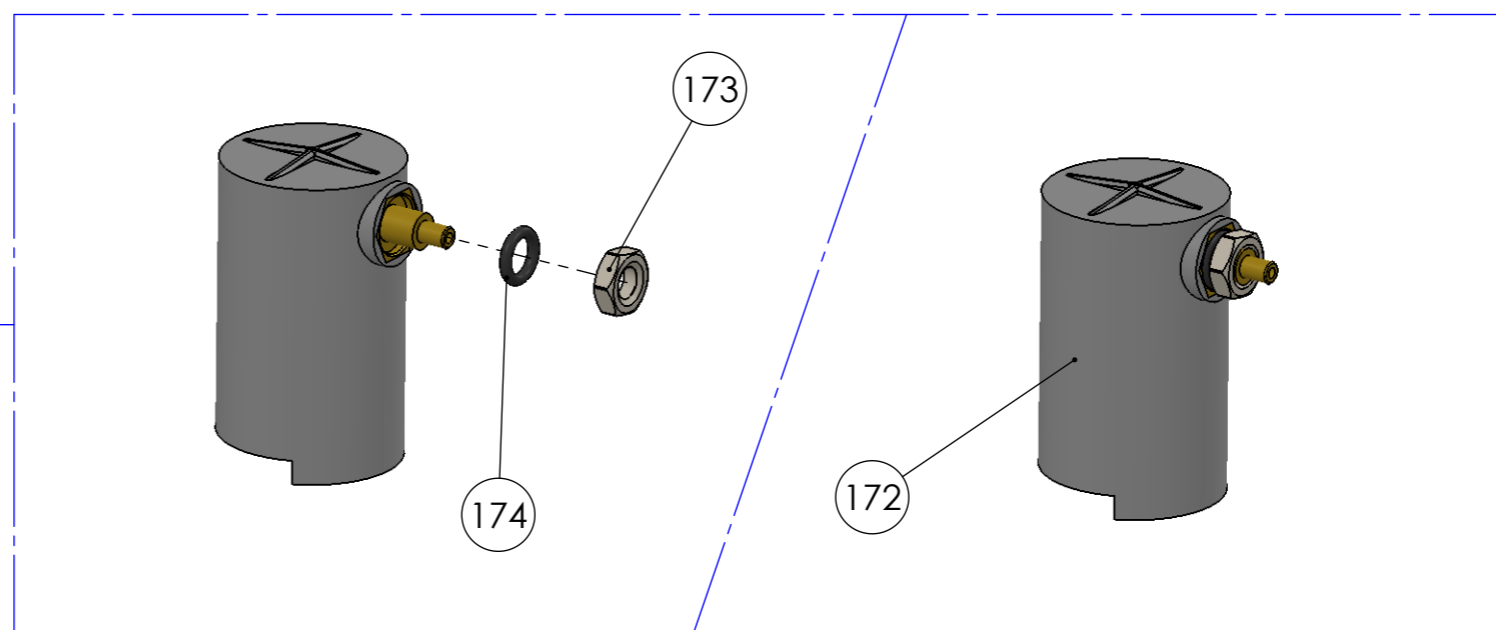
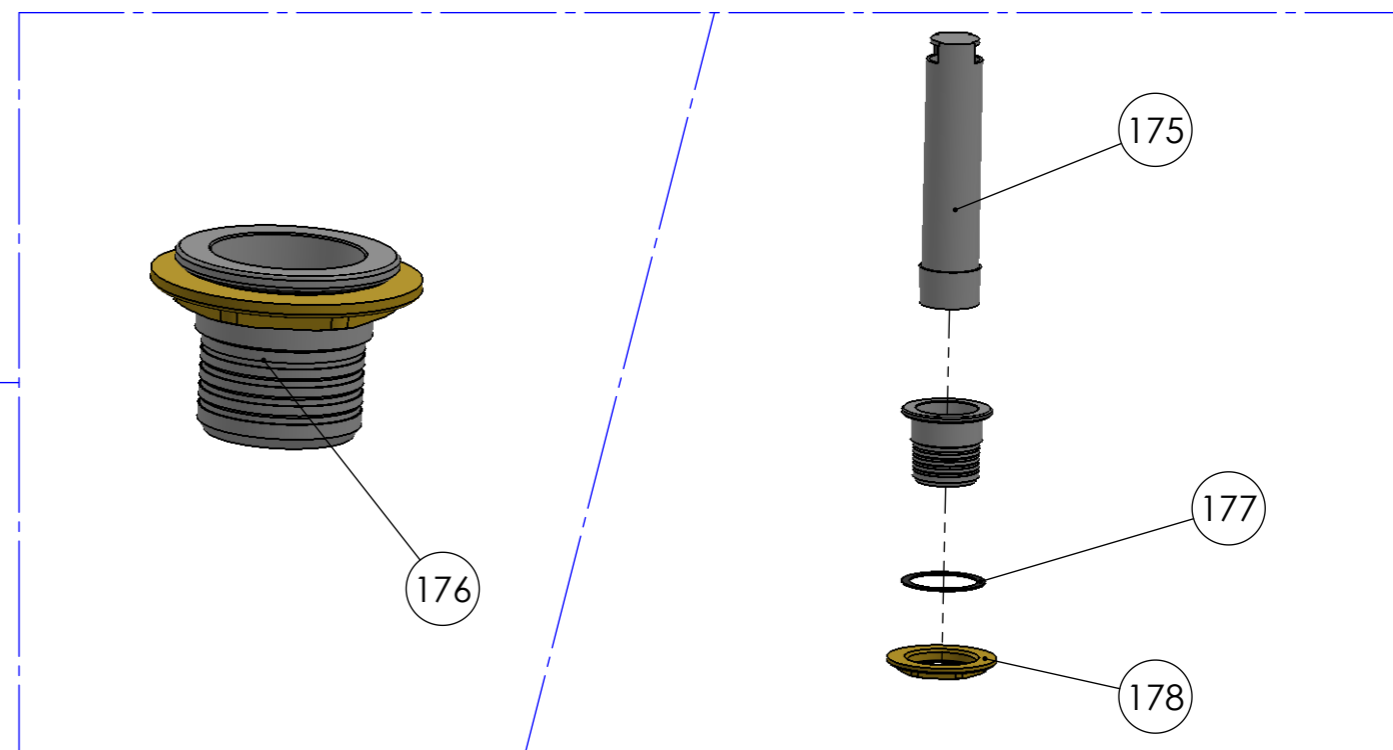
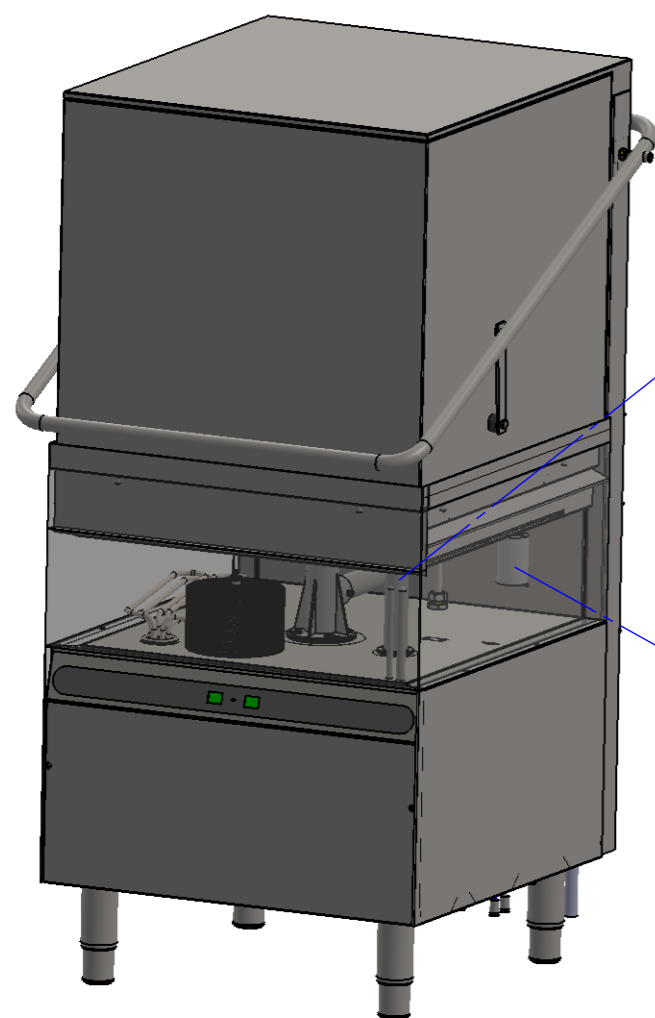

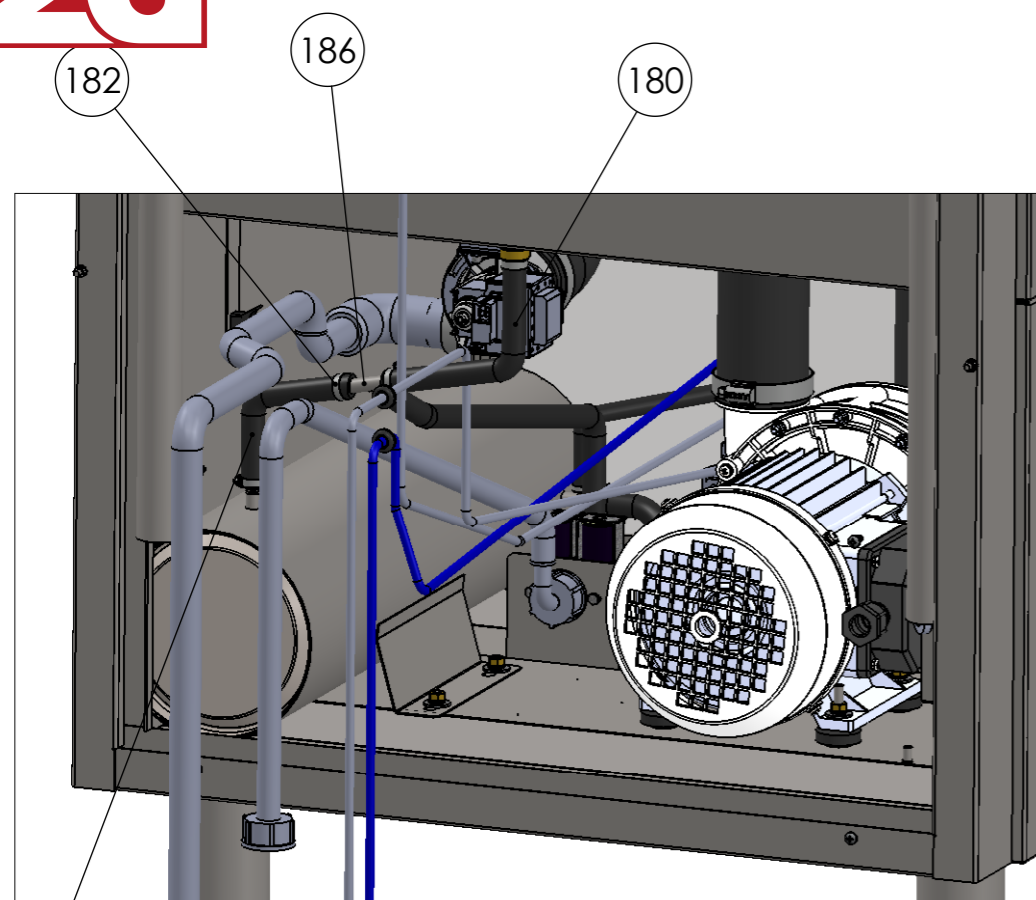

ITEM NO.	REF.	DESCRIPTION	QTE.
179	003.00.00140_13	TURBO CRISTAL 4X6	1
180	002.00.00119-20	TUYAU DE MACHINE À LAVER NOIR 10X16.5	1
181	003.00.00140_12	TURBO CRISTAL 4X6	1
182	002.00.00052	SERRE-JOINT 10-16	8
183	002.00.00132-4	TUYAU DE MACHINE À LAVER NOIR 6X12	1
184	002.00.00231	SERRE-JOINT 8-12	2
185	002.00.00119-23	TUYAU DE MACHINE À LAVER NOIR 10X16.5	1
186	002.51.00007	T-CONNECTION SURCHAUFFEUR KNOSSOS	1
187	002.00.00119-22	TUYAU DE MACHINE À LAVER NOIR 10X16.5	1

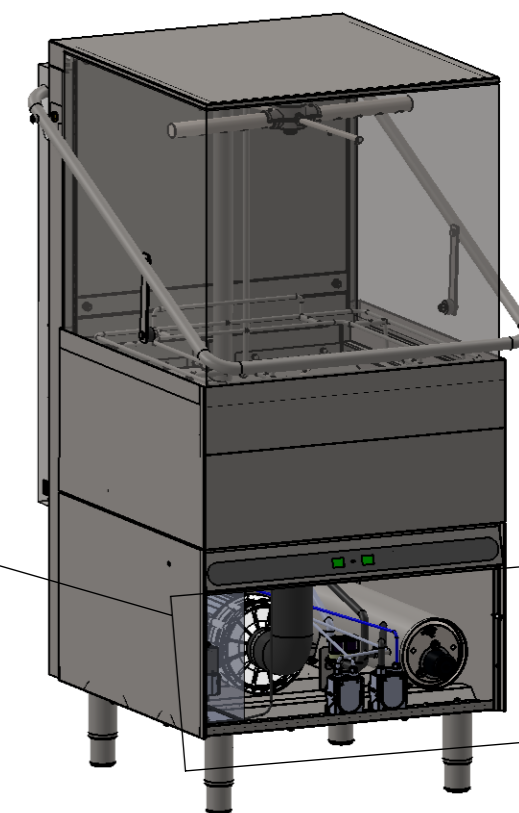
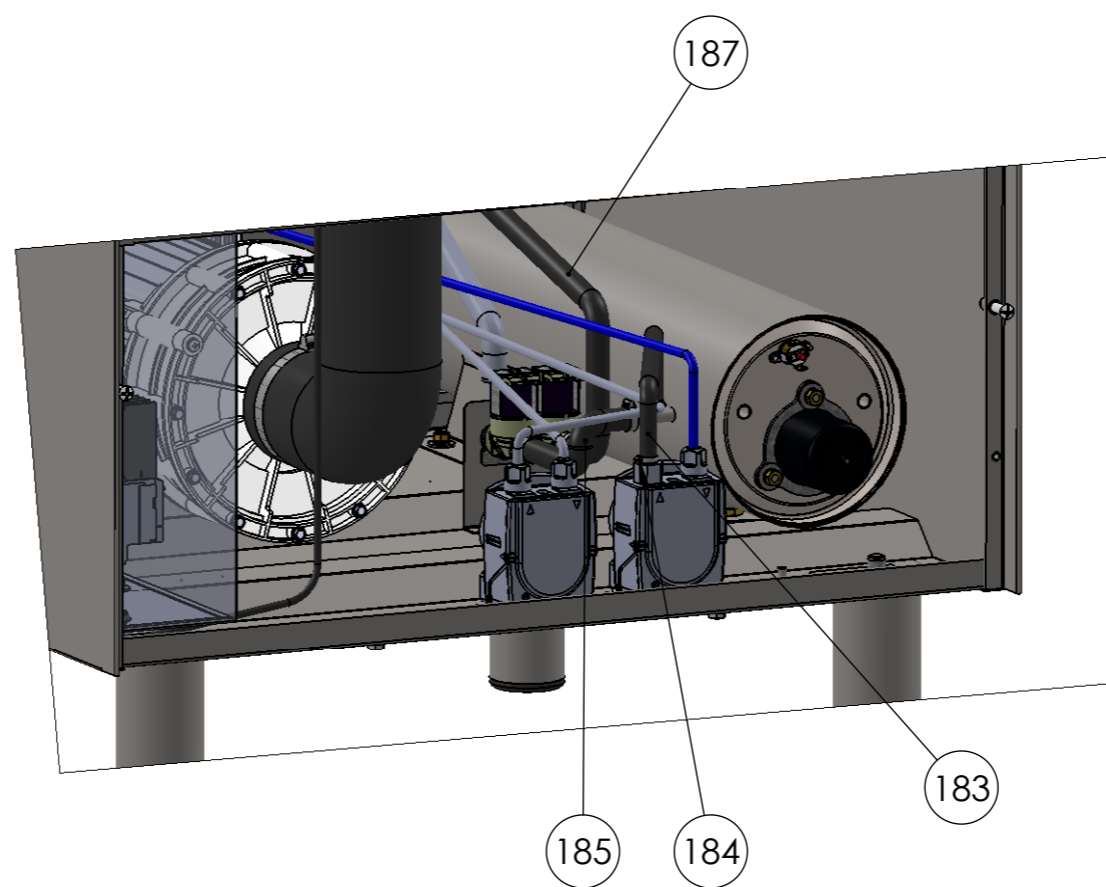
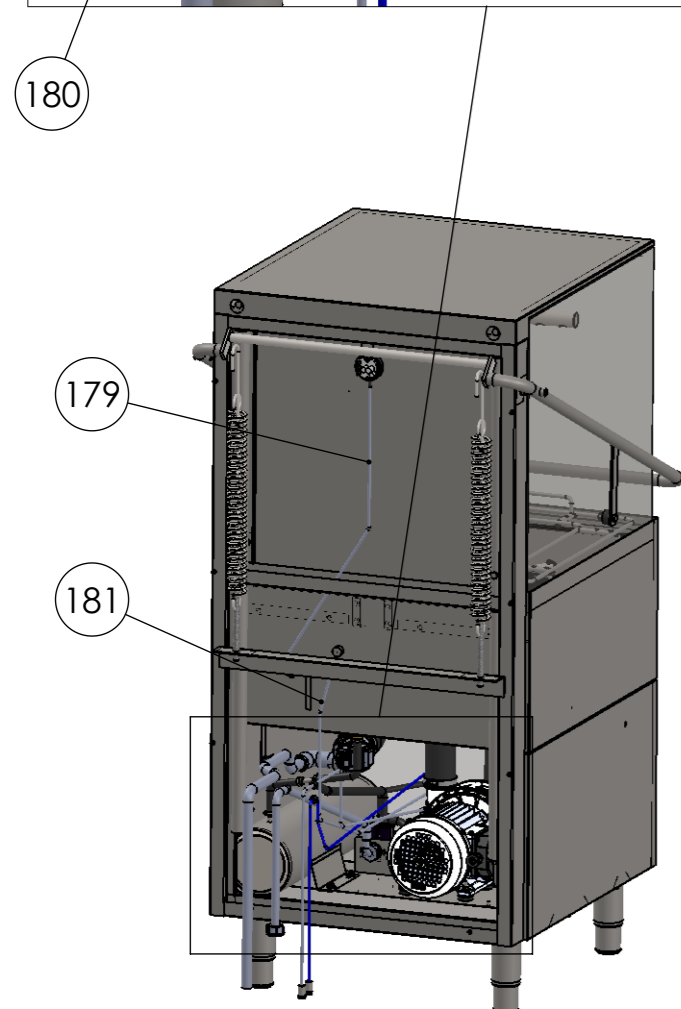

SERIES DESCRIPTION:
LAVE-VAISSELLE

MODEL DESCRIPTION:
1510

MODEL VERSION:
380V-415V 3~N 50/60 Hz

MODEL CODE:
004.15.00027

PAGE:
18

REVISION:
01