

ITEM NO.	REF.	DESCRIPTION	/QTE.
2	001.50.00048	CAPOT AVANT INOX V50	1
3	001.50.00046	PORTE COMPLET V50 - K50	1
5	001.00.00045	TEFLON RONDELLE $\Phi 12,5 \times 8 \times 2,5$	2
6	001.00.00051	ENSEMBLE DE PORTES	2
7	001.00.00213	VIS INOX M4X15	2
8	001.00.00117	ECROU DOME M4	2
9	002.00.00095	ECROU INOX M4	2
10	002.00.00140	RONDELLE SERRAGE INOX $\Phi 4$	2
11	001.00.00016	PETIT PIED NOIR V500	4
12	001.50.00043-1	CAPOT ARRIERE INOX V50 - K50	1
13	001.00.00221	GUIDE PLASTIQUE POUR ESSIEU PORTE	2
14	001.00.00048-M	PORTE GAUCHE AXE DE SUPPORT M6X300	1
15	001.00.00048	PORTE DROITE AXE DE SUPPORT M6X300	1
16	001.00.00110	ECROU DOME CAP M6	2
17	001.00.00073	VIS INOX 2,9 X 10	4
20	001.50.00015	COUVERCLE SUPÉRIEUR INOX V50 - K50	1

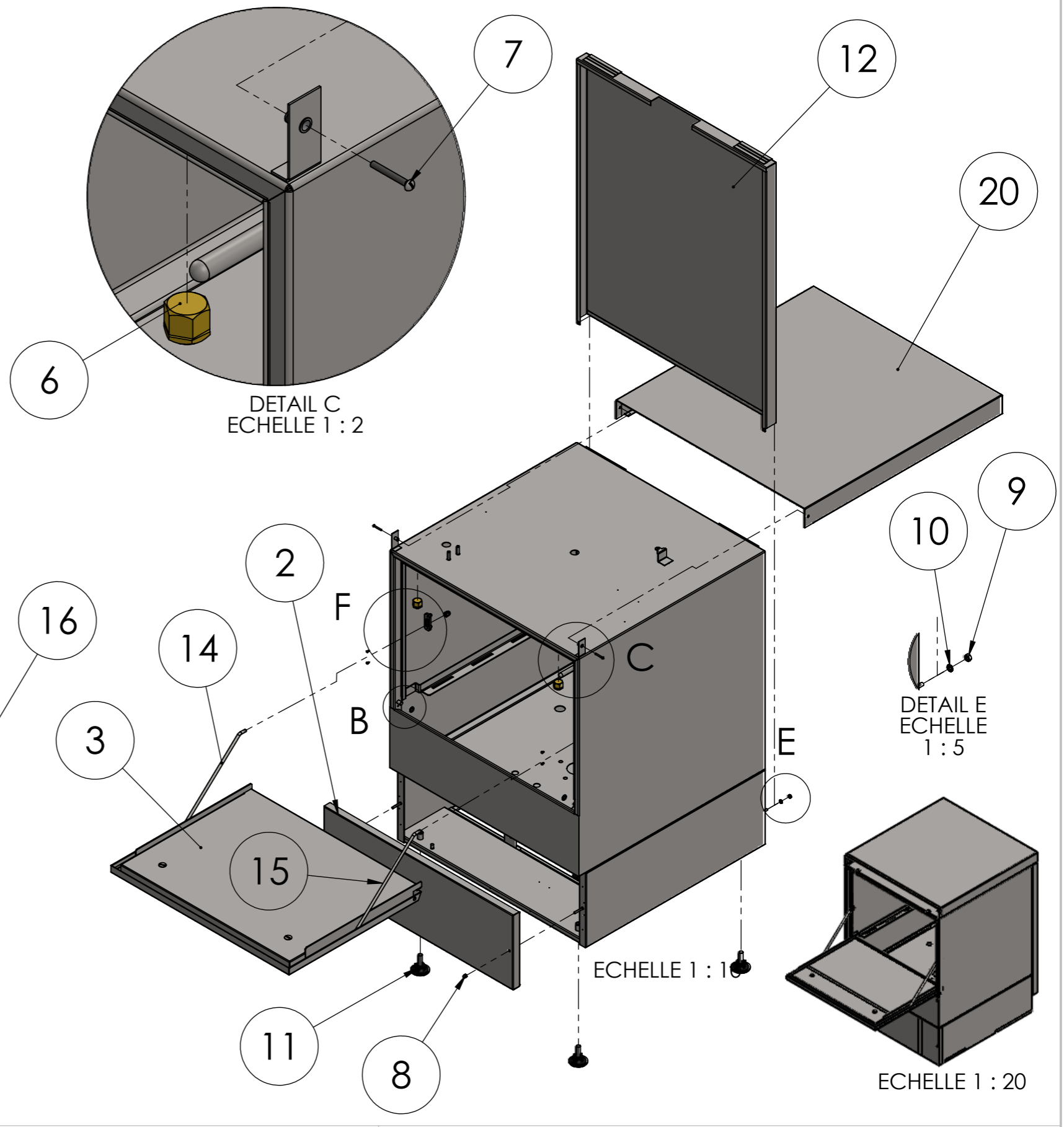

SERIES DESCRIPTION: UNDERCOUNTER

MODEL: EM-LV50

ITEM CODE:

MODEL VERSION: 230V ~N 50/60Hz

ITEM DESCRIPTION: STRUCTURE ACIER

MODEL CODE: 004.50.00009

PAGE: 1

REVISION: 0

ITEM NO.	REF.	DESCRIPTION	QTE.
11	001.50.00011	PARTIE ARRIÈRE DE LA PORTE V-K	1
12	001.50.00027	PARTIE AVANT DE LA PORTE V-K	1
3	001.00.00118	POIGNÉE DE PORTE COMPLÈTE V-K	1
4	002.00.00057	POIGNÉE DE PORTE BRIDE EN PLASTIQUE	2
10	003.00.00211	VIS TETE FRAISEE INOX M8X30	2

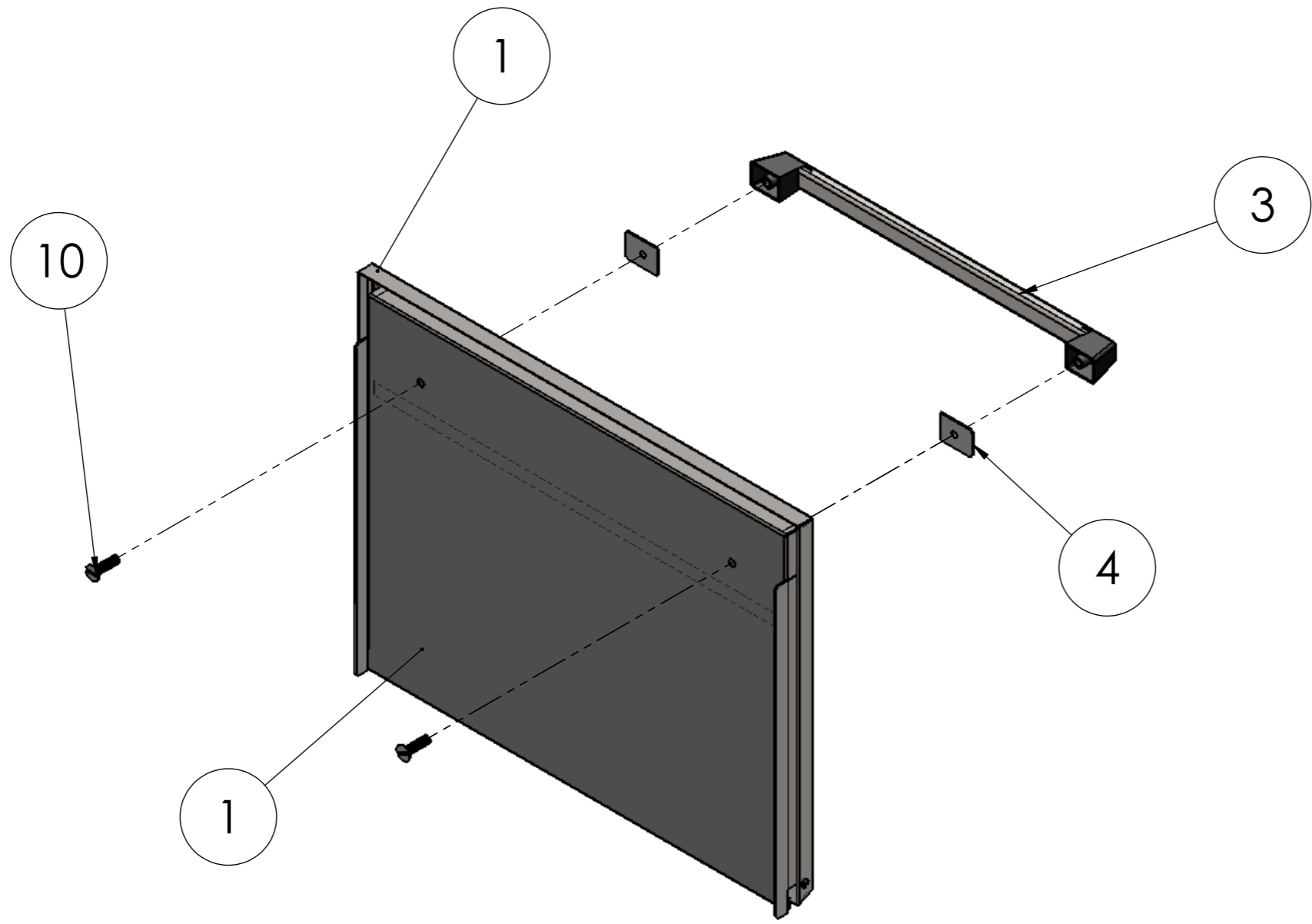

ECHELLE 1 : 5

SERIES DESCRIPTION: UNDERCOUNTER		MODEL: EM-LV50	ITEM CODE: 001.50.00046	ITEM DESCRIPTION: PORTE COMPLETE V50 - K50		
			MODEL VERSION: 230V~N 50/60Hz	MODEL CODE:004.15.00000	PAGE: 1	REVISION: 0

ITEM NO.	REF.	DESCRIPTION	QTE.
2	003.00.00494	SERRE-CÂBLE EN PLASTIQUE	2
3	002.00.00140	RONDELLE INOX $\Phi 4$	4
4	003.00.00046	ECROU M4 (GALV)	4
5	003.50.00002	PANNEAU AFFICHAGE COMPLET V50	1
6	006.50.00002	BOITIER ELECTRIQUE COMPLET 230V~N 50/60Hz	1

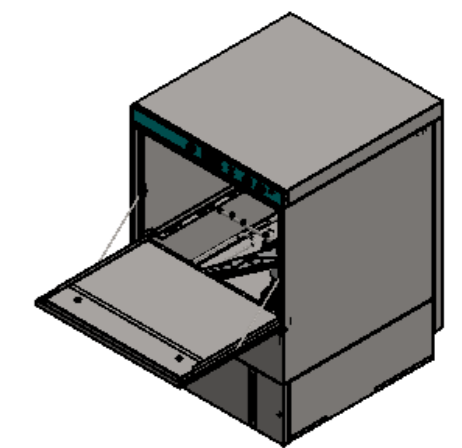
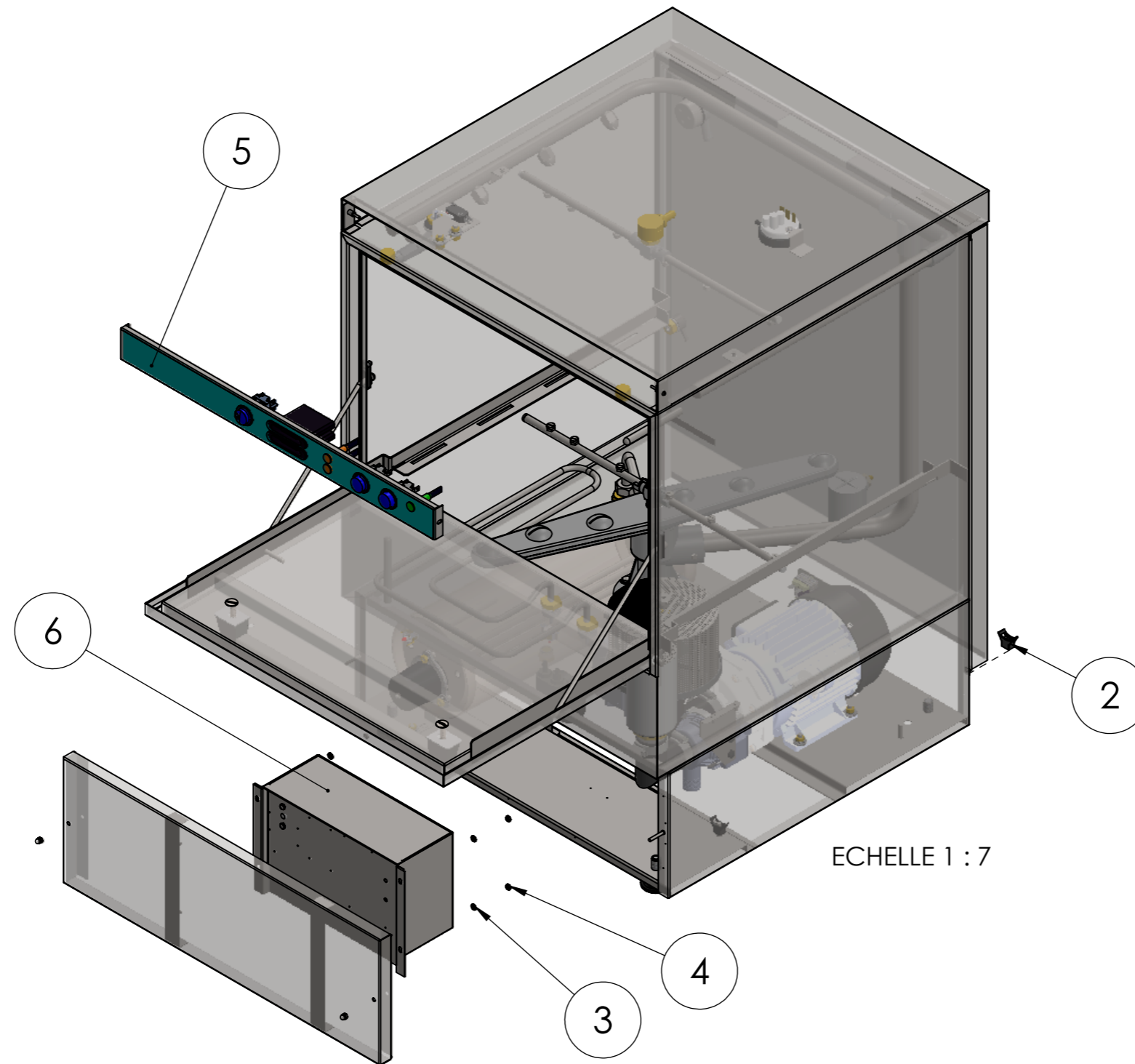

ECHELLE 1 : 20

ECHELLE 1 : 7

ITEM CODE:	ITEM DESCRIPTION: ÉQUIPEMENT ÉLECTRIQUE				
SERIES DESCRIPTION: UNDERCOUNTER	MODEL: EM-LV50	MODEL VERSION: 230V~N 50/60Hz	MODEL CODE:004.50.00090	PAGE: 1	REVISION:

ITEM NO.	REF.	DESCRIPTION	QTE.
1	001.50.00044	PANNEAU D'INTERRUPTEURS INOX V50	1
8	003.50.00009	MEMBRANE	1
3	003.00.00505	THERMOMERTE 2500mm	2
4	003.00.00564	INTERRUPTEUR DÉMARRAGE AUTOUR DE DEUX CONTACTS	2
5	003.00.00028	VOYANT ORANGE	2
6	003.00.00176	VOYANT VERT	1
7	003.00.00563	INTERRUPTEUR MARCHÉ-ARRÊT 4 CONT.	1

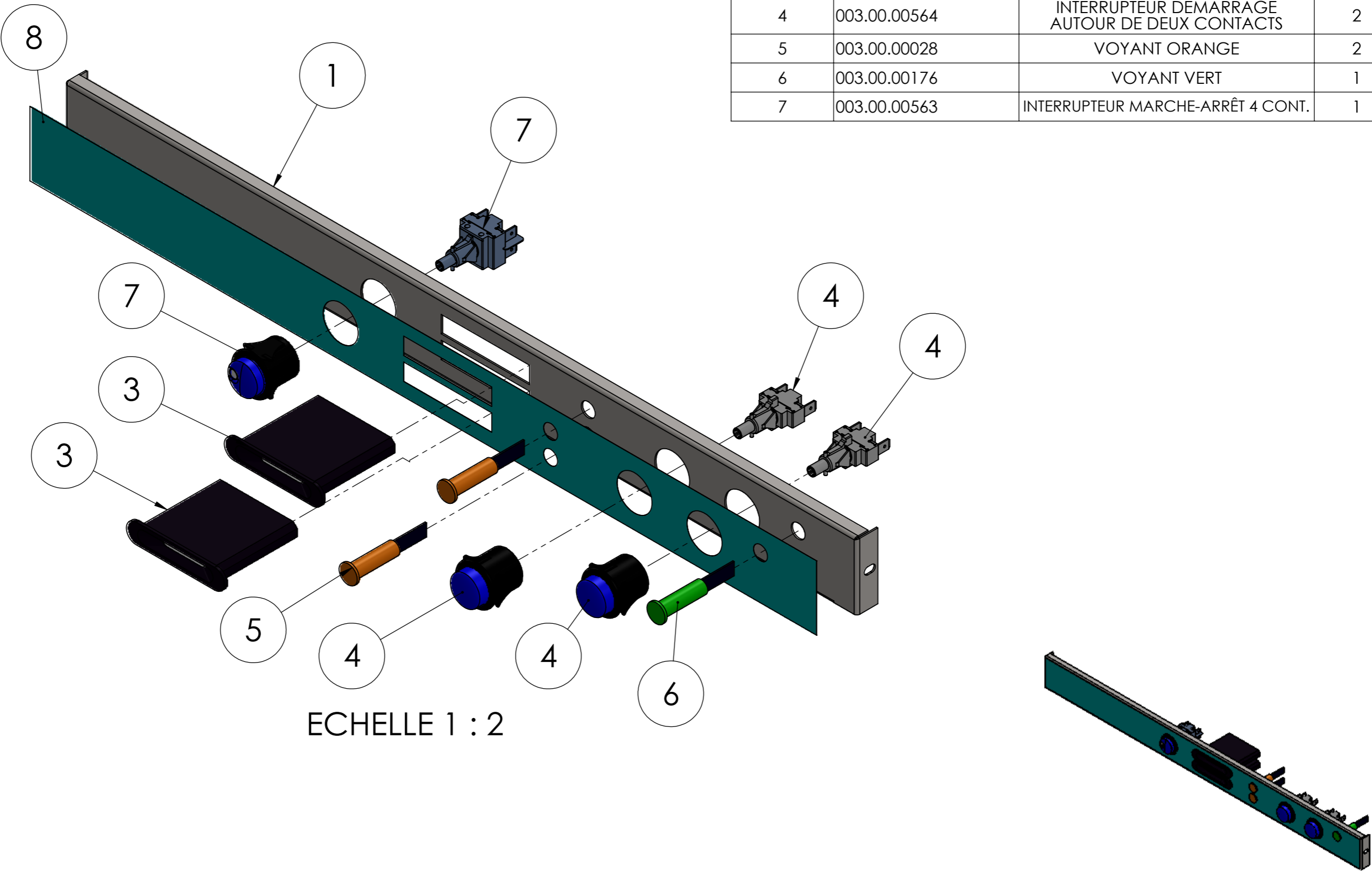

ECHELLE 1 : 2

SERIES DESCRIPTION: UNDERCOUNTER		MODEL: EM-LV50	ITEM CODE: 003.50.00002	ITEM DESCRIPTION: PANNEAU CONTROLE COMPLET V50	
		MODEL VERSION: 230V~N 50/60Hz	MODEL CODE:004.50.00090	PAGE: 1	REVISION: 0

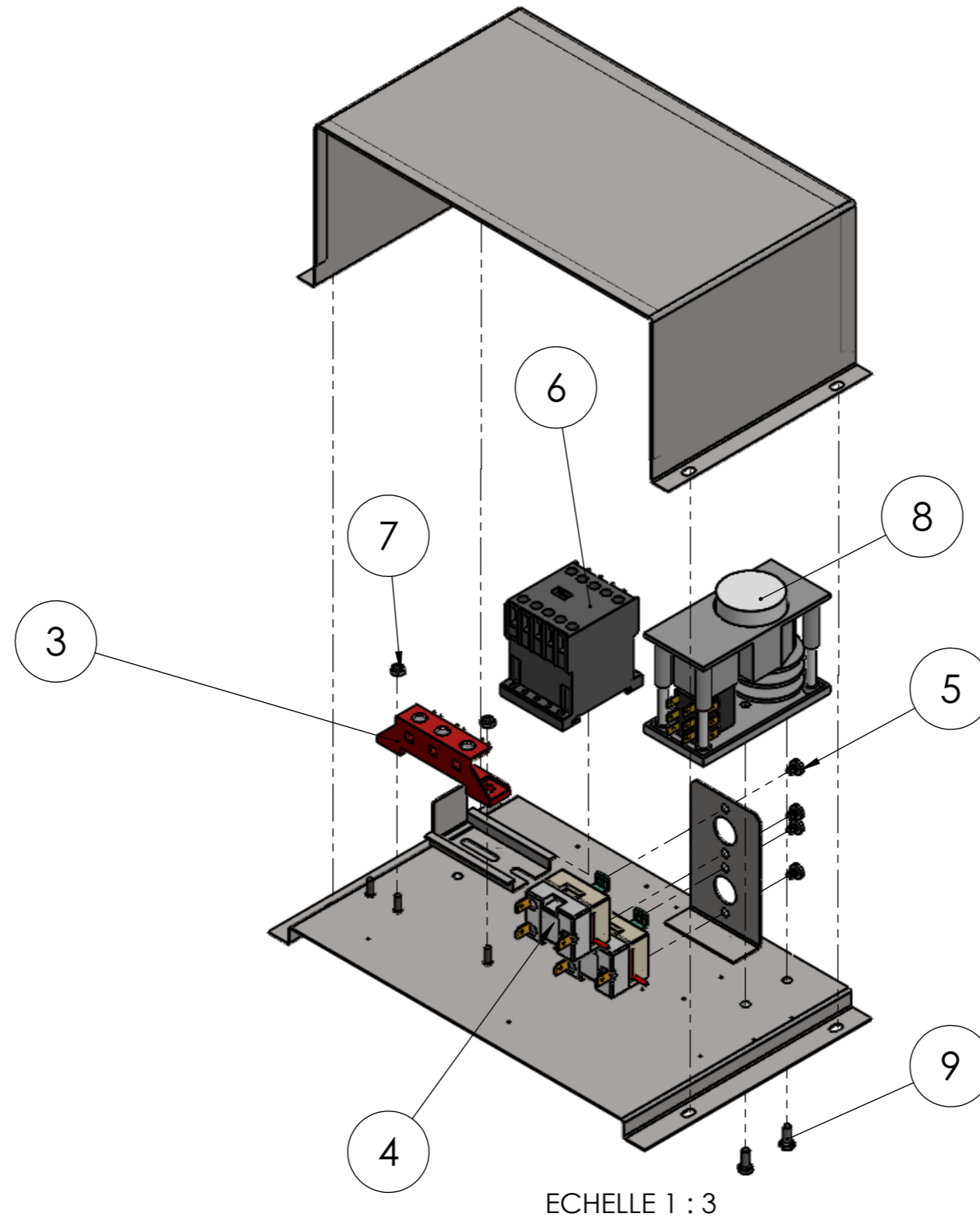

ITEM NO.	REF.	DESCRIPTION	QTE.
3	003.00.00392	PANNEAU D'ALIMENTATION ÉLECTRIQUE TROIS CON.	1
4	003.00.00213	THERMOSTAT 0-90°C 1500mm	2
5	001.00.00076	VIS GALVANISE W M4 X 5	4
6	003.00.00056	CONTACTEUR MAGNÉTIQUE	1
7	003.00.00046	ECROU M4 (GALV)	2
8	003.00.00448	TIMER 120 SEC. Q.START	1
9	003.00.00278	BOULON GALV. M4X10	2

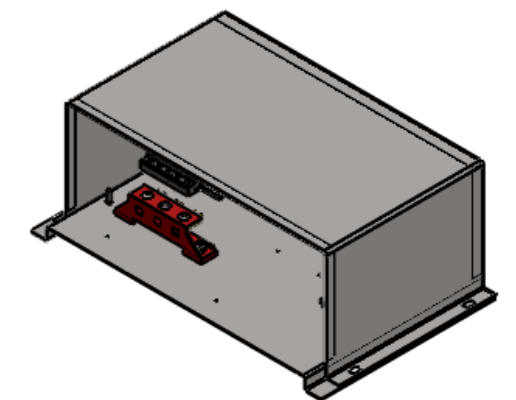

ITEM CODE: 006.50.00002

ITEM DESCRIPTION: BOITIER ELECTRIQUE

SERIES DESCRIPTION: UNDERCOUNTER

MODEL: EM-LV50

MODEL VERSION: 230V ~ N 50/60Hz

MODEL CODE:004.50.00090

PAGE: 1

REVISION: 0



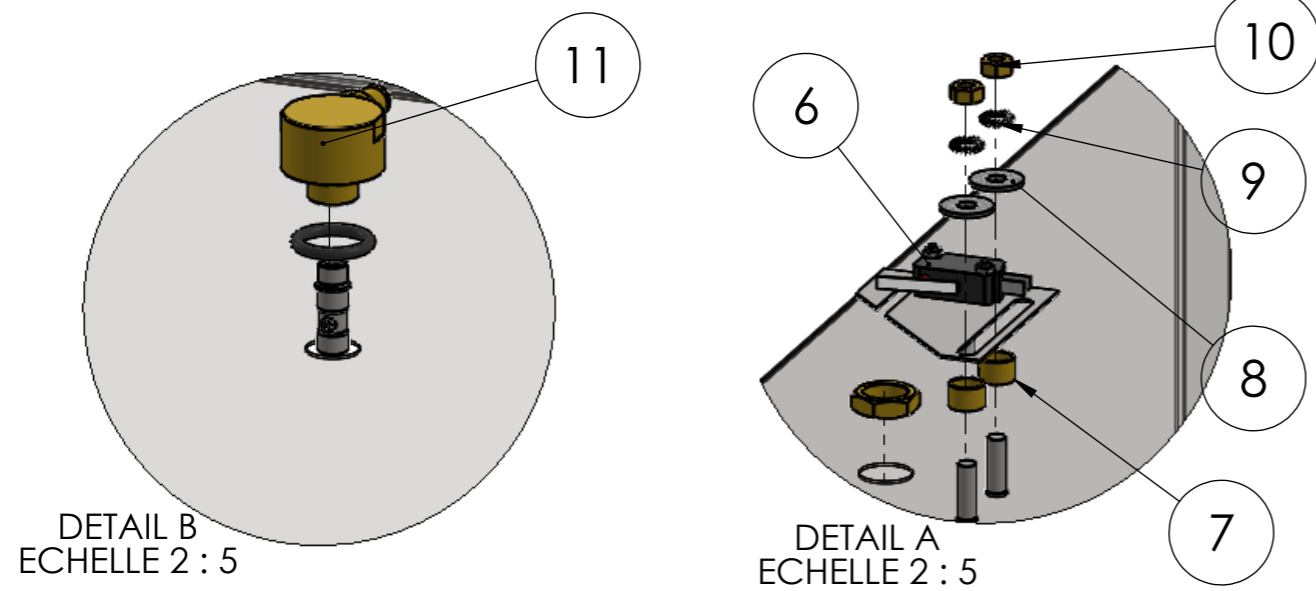

ITEM NO.	REF.	DESCRIPTION	QTE.
5	003.00.00231	INTERRUPTEUR DE PORTE MECH. PARTIE	1
6	003.00.00426	COMMUTATEUR DE PORTE EL. PART 35-40-50 COMPLET	1
7	003.00.00085	ENTRETOISE POUR INTERRUPTEUR DE PORTE	2
8	003.00.00516	RONDELLE ACIER $\Phi 6 \times 18$	2
9	001.00.00204	RONDELLE GALVANISE 6,4x11x0,7	2
10	003.00.00041	ECROU M6 GALVANISE	2
11	002.35.00029	BASE DE RINÇAGE SUPÉRIEURE COMPLÈTE	1
12	003.00.00033	PRESSOSTAT	1
13	003.00.00200	vis autotaraudeuse 3.5X9.50	1
25	002.50.00026	BRAS DE RINÇAGE EN HAUT OU EN BAS V-K	2
26	002.50.00004-1	ECROU SERRAGE POUR BRAS DE RINÇAGE	2

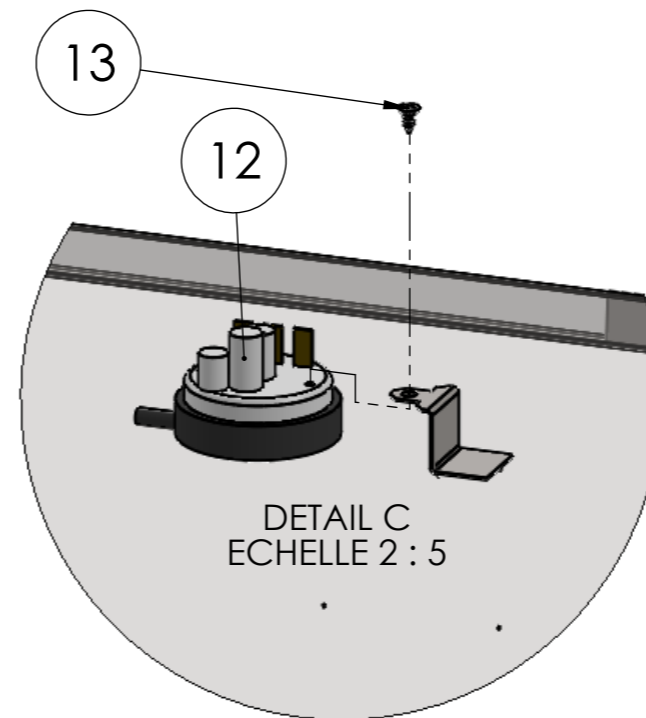
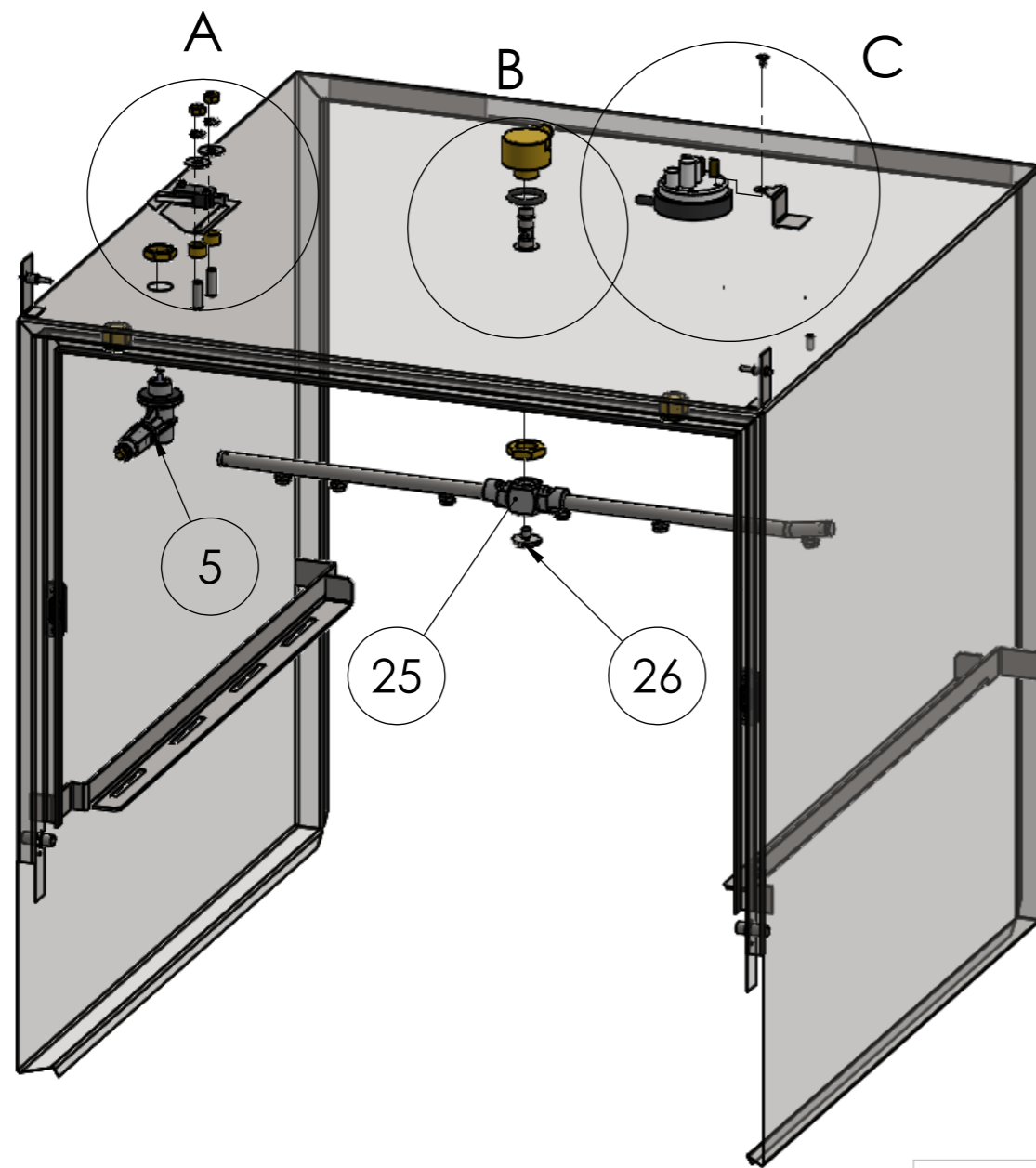

ITEM CODE:

ITEM DESCRIPTION: EQUIPEMENT MECANIQUE

SERIES DESCRIPTION: UNDERCOUNTER

MODEL: EM-LV50

MODEL VERSION: 230V~N 50/60Hz

MODEL CODE:004.50.00090

PAGE: 3

REVISION: 0

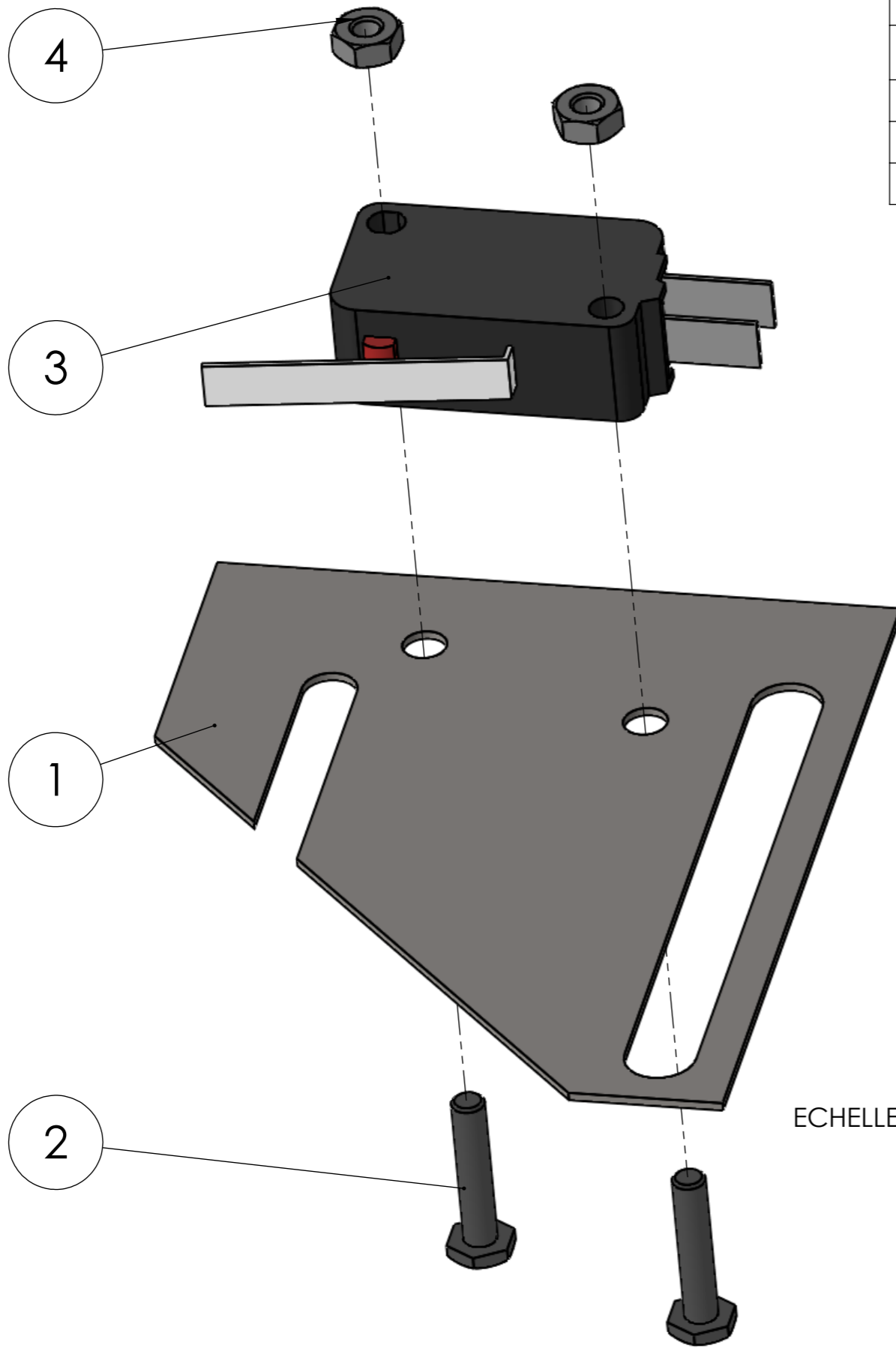

ECHELLE 2 : 1

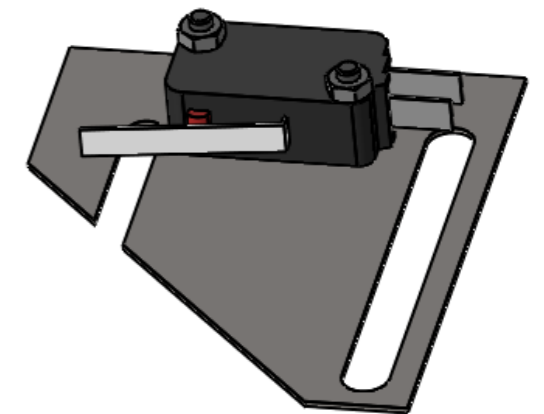

ITEM NO.	REF.	DESCRIPTION	QTE.
1	003.00.00077	BASE EN INOX POUR L'INTERRUPTEUR ÉLECTRIQUE DE LA PORTE	1
2	003.00.00065	BOULON GALV. HEX. M3X16	2
3	003.00.00069	MICRO-INTERRUPTEUR DE PORTE	1
4	002.00.00090	ECROU GALV. M3	2

ITEM CODE: 003.00.00426

ITEM DESCRIPTION: DOOR SWITCH ELECTRICAL PART COMPLETE

SERIES DESCRIPTION: UNDERCOUNTER MODEL DESCRIPTION: VE50

MODEL VERSION: 230V~N  
50/60Hz

MODEL CODE:004.50.00009

PAGE:

REVISION:

ITEM NO.	REF.	DESCRIPTION	QTE.
3	002.50.00036	BASE DE LAVAGE BAS V-K COMPLET	1
9	001.00.00204	RONDELLE GALVANISE 6,4x11x0,7	4
10	003.00.00041	ECROU M6 GALVANISE	4
16	002.00.00062	ECROU 1/2	1
22	002.50.00016	DISQUE DE CONTRÔLE DE FLUX POUR LA BASE V-K	1
23	002.11.00002	ESSIEU INOX POUR BASE EN BAS V500	1
24	002.50.00006		1
25	002.50.00026	BRAS DE RINÇAGE HAUT OU BAS V-K	2
26	002.50.00004-1	ECROU BRAS DE RINÇAGE	2
27	002.50.00022	TUYAU DE RINÇAGE INOX V-K	1
28	002.00.00144	ECROU MAINTIEN DE LA CONDUITE DE RINÇAGE	2
29	002.00.00091	JOINT 3X10,5	2
52	002.50.00018	SYSTÈME DE LAVAGE SUPÉRIEUR TUYAU D'ALIMENTATION EN INOX	1
53	002.50.00017	SYSTÈME DE LAVAGE DES CONNECTEURS EN PLASTIQUE	1
54	002.50.00019	SYSTÈME DE LAVAGE SUPÉRIEUR INOX HAUT-GAUCHE	1
55	002.50.00020	SYSTÈME DE LAVAGE SUPÉRIEUR MONTANT INOX	1
57	003.00.00104	BOULON INOX HEX M6X20	4
58	002.00.00169	TEFLON 12-6-2	4

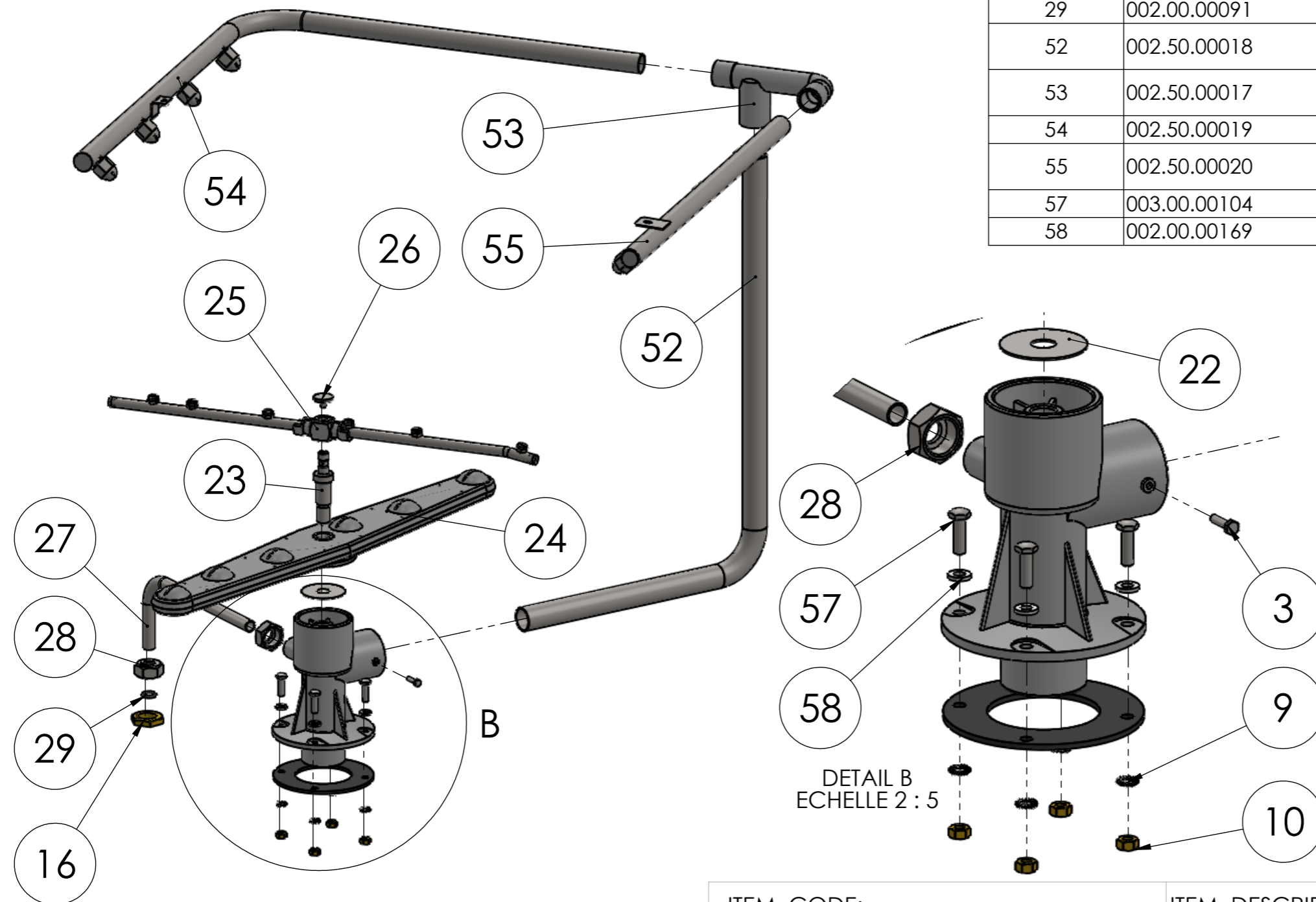

ITEM CODE:

ITEM DESCRIPTION: EQUIPEMENT MECANIQUE

SERIES DESCRIPTION: UNDERCOUNTER

MODEL: EM-LV50

MODEL VERSION: 230V ~ N 50/60Hz

MODEL CODE: 004.50.00090

PAGE: 4

REVISION: 0



ITEM NO.	REF.	DESCRIPTION	QTE.
3	002.00.00229	TEFLON $\Phi$ 23X10	2
4	003.00.00424	VIS INOX 4,2 X 13	12

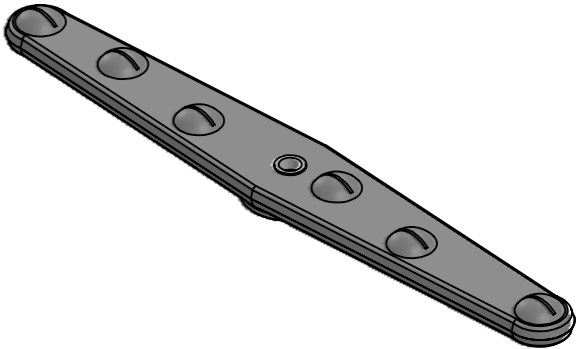
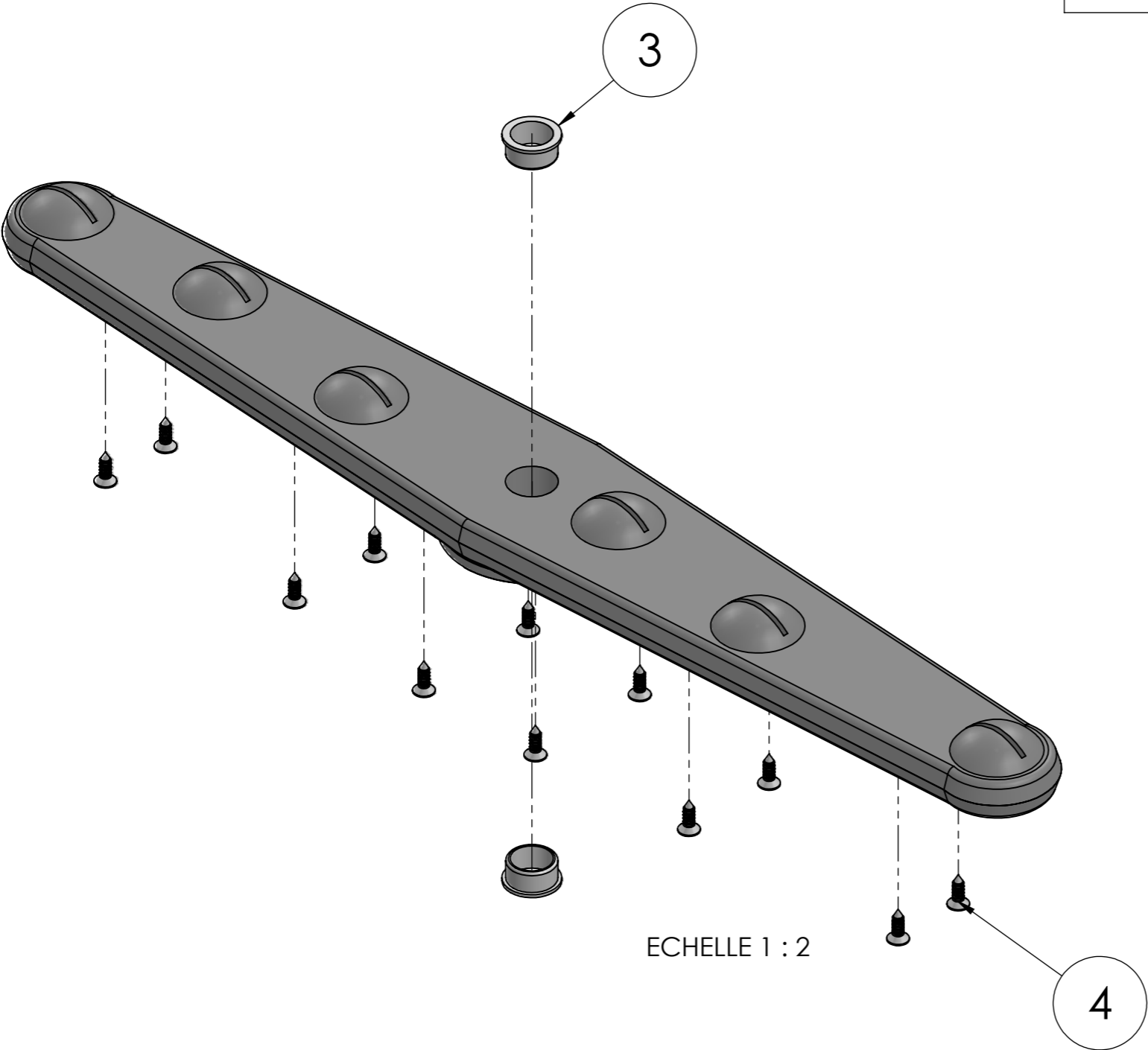

SERIES DESCRIPTION: UNDERCOUNTER MODEL: EM-LV50		ITEM CODE: 002.50.00006	ITEM DESCRIPTION:		
		MODEL VERSION: 230V~N 50/60Hz	MODEL CODE:004.50.00090	PAGE: 1	REVISION: 0

ITEM NO.	REF.	DESCRIPTION	QTE.
1	002.50.00025	BASE EN PLASTIQUE POUR LE BRAS DE RINÇAGE	1
2	002.50.00005 (B)	BRAS DE RINÇAGE SIMPLE - B	1
3	002.50.00005 (A)	BRAS DE RINÇAGE - A	1
4	002.00.00230	TEFLON $\Phi$ 18X6	2
5	002.11.00008	PULVÉRISATEUR POUR BRAS DE RINÇAGE	6
6	002.35.00047	BOUCHON POUR BRAS DE RINÇAGE	2

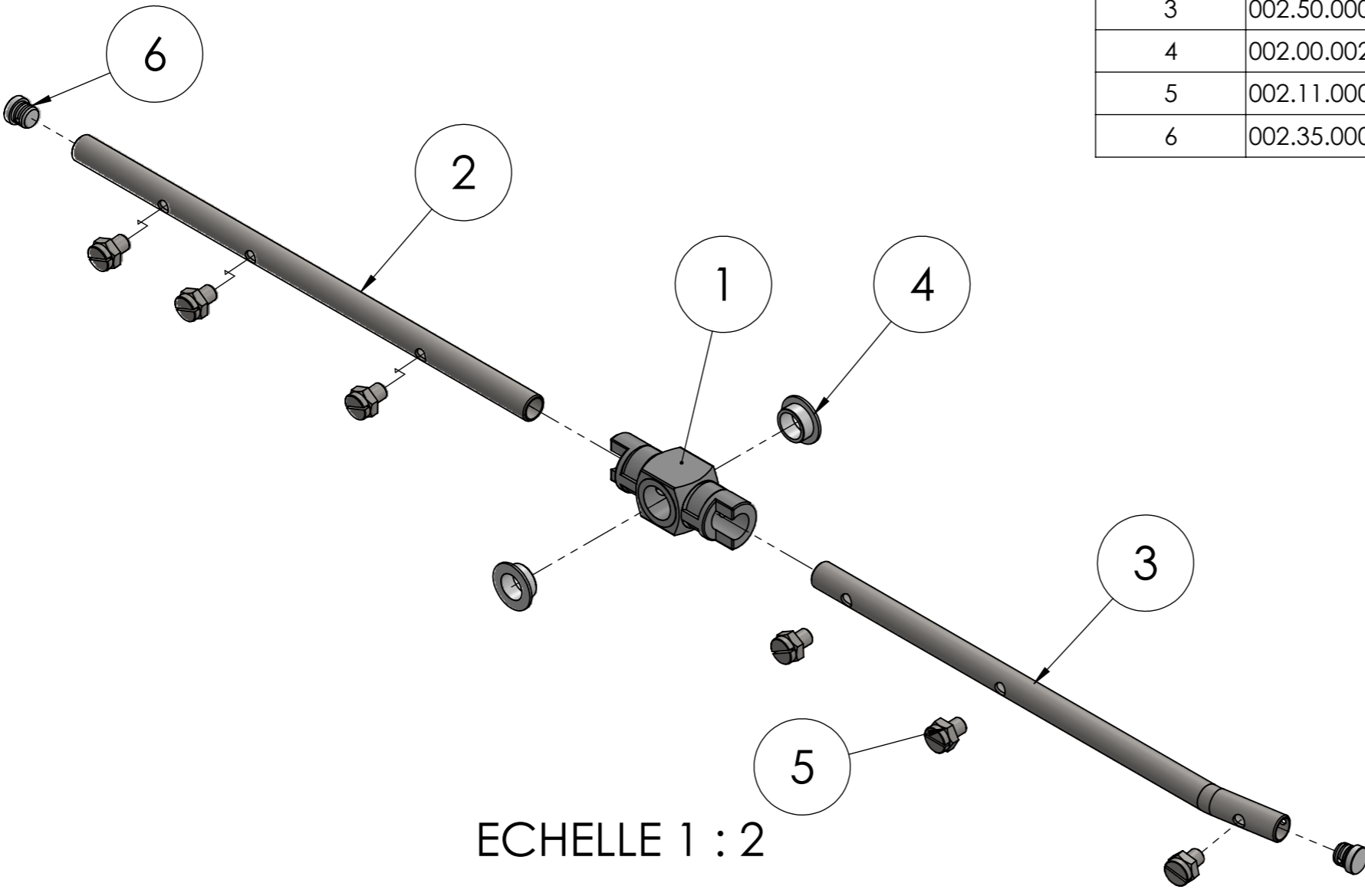

ECHELLE 1 : 2



SERIES DESCRIPTION: UNDERCOUNTER		MODEL: EM-LV50	ITEM CODE: 002.50.00026	ITEM DESCRIPTION: BRAS DE RINÇAGE HAUT OU BAS V-K	
		MODEL VERSION: VERGINA 50 230V~N 50/60HZ	MODEL CODE: 004.50.00090	PAGE: 1	REVISION: 0

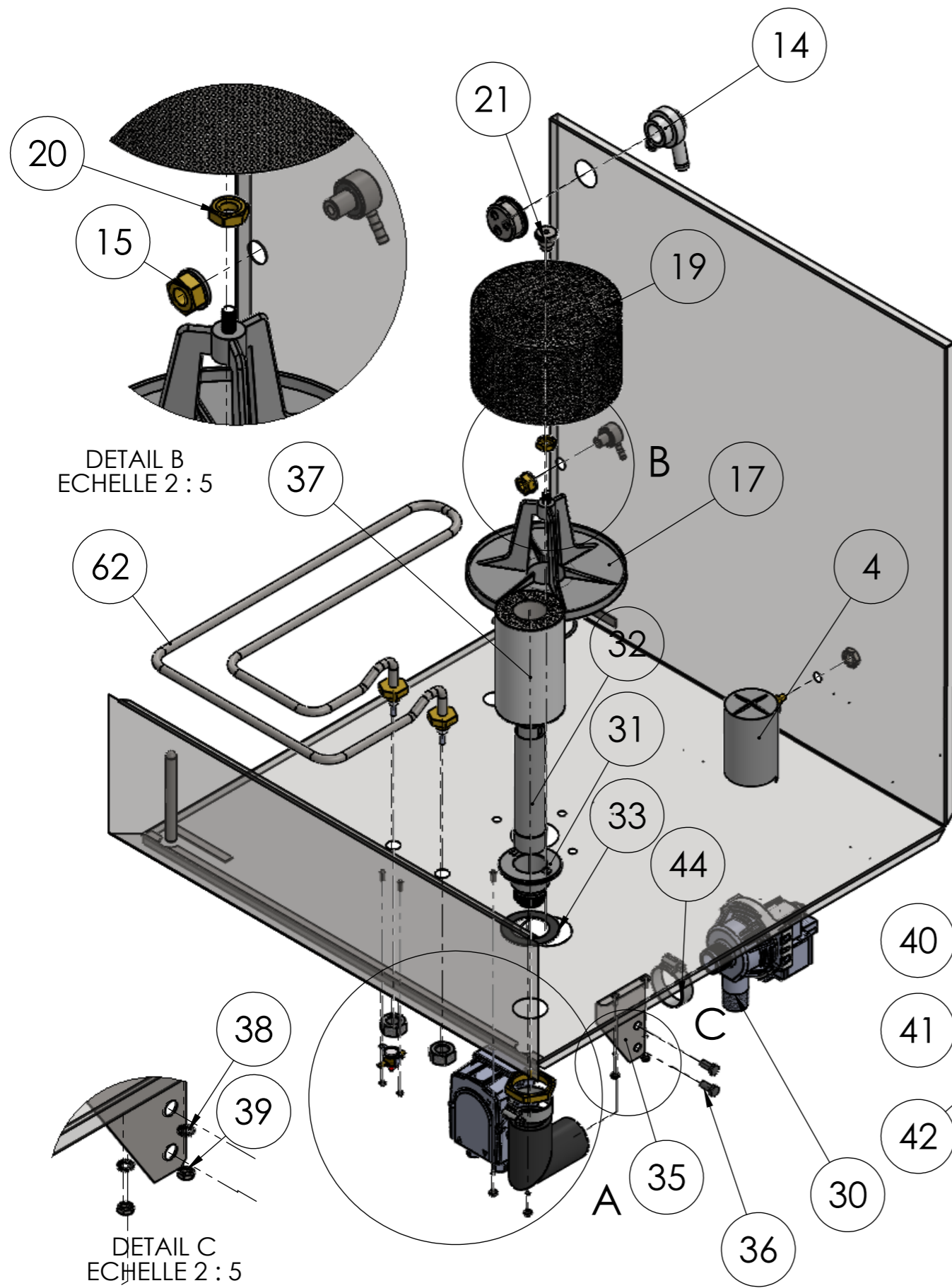

ITEM NO.	REF.	DESCRIPTION	QTE.
4	003.00.00014	CHAMBRE PRESSOSTATIQUE	1
14	003.00.00269	VALVE DE NON-RETOUR (DVGW)	1
15	002.00.00233	INJECTEUR DE RÉSERVOIR DE DÉTERGENT	1
17	002.00.00081	BASE EN PLASTIQUE POUR FILTRE À RÉSERVOIR V-K	1
19	002.70.00000	FILTRE DANS LE RÉSERVOIR POUR LA POMPE V-K	1
20	001.00.00093	M10 ECROU INOX	1
21	001.00.00017	RÉTENTION DU FILTRE ECROU	1
30	003.00.00184	POMPE DE VIDANGE DE RÉSERVOIR 230V / 65W	1
31	002.00.00257	SOUPAPE DE VIDANGE ET DE TROP-PLEIN BASE EN PLASTIQUE	1
32	002.70.00013	SOUPAPE DE VIDANGE ET DE TROP-PLEIN PARTIE EN PLASTIQUE NOUVEAU V-K	1
33	002.00.00238	JOINT D'ÉTANCHÉITÉ EN CAOUTCHOUC 35X55X1	1
34	002.00.00133	ECROU BRONZE M36	1
35	001.50.00065	BASE FOR DRAINING PUMP INOX V500	1
36	003.00.00485	BOULON GALVA M6	2
37	001.50.00040	FILTRE DE LA POMPE DE VIDANGE V500	1
38	002.00.00140	RONDELLE INOX Ø4	4
39	003.00.00046	ECROU M4 (GALV)	4
40	003.00.00074	ECROU 14 (GALV.)	2
41	003.00.00168	THERMOFUSIBLE DE RÉSERVOIR 90°C	1
42	002.00.00090	ECROU GALV. M3	2
43	002.50.00014	TUYAU D'ENTRÉE DE LA POMPE DE VIDANGE V500	1
44	002.00.00048	SERRE-JOINT 25-40	2
46	003.00.00429	POMPE À DÉTERGENT PÉRISTALTIQUE G300 / 230V	1
62	003.50.00008	RÉSERVOIR DE L'ÉLÉMENT CHAUFFANT 2,8 kW / 230V	1

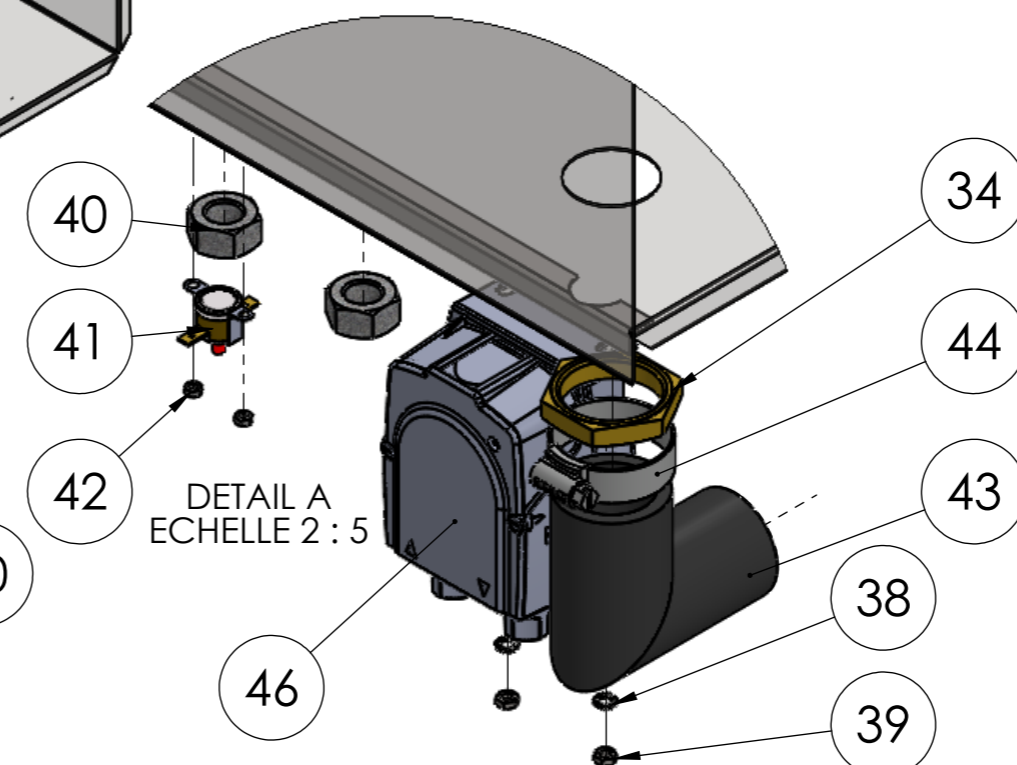

ITEM CODE:	ITEM DESCRIPTION: EQUIPEMENT MECANIQUE
MODEL VERSION: 230V~ N 50/60Hz	MODEL CODE:004.50.00090
SERIES DESCRIPTION: UNDERCOUNTER	PAGE: 1
MODEL: EM-LV50	REVISION: 0

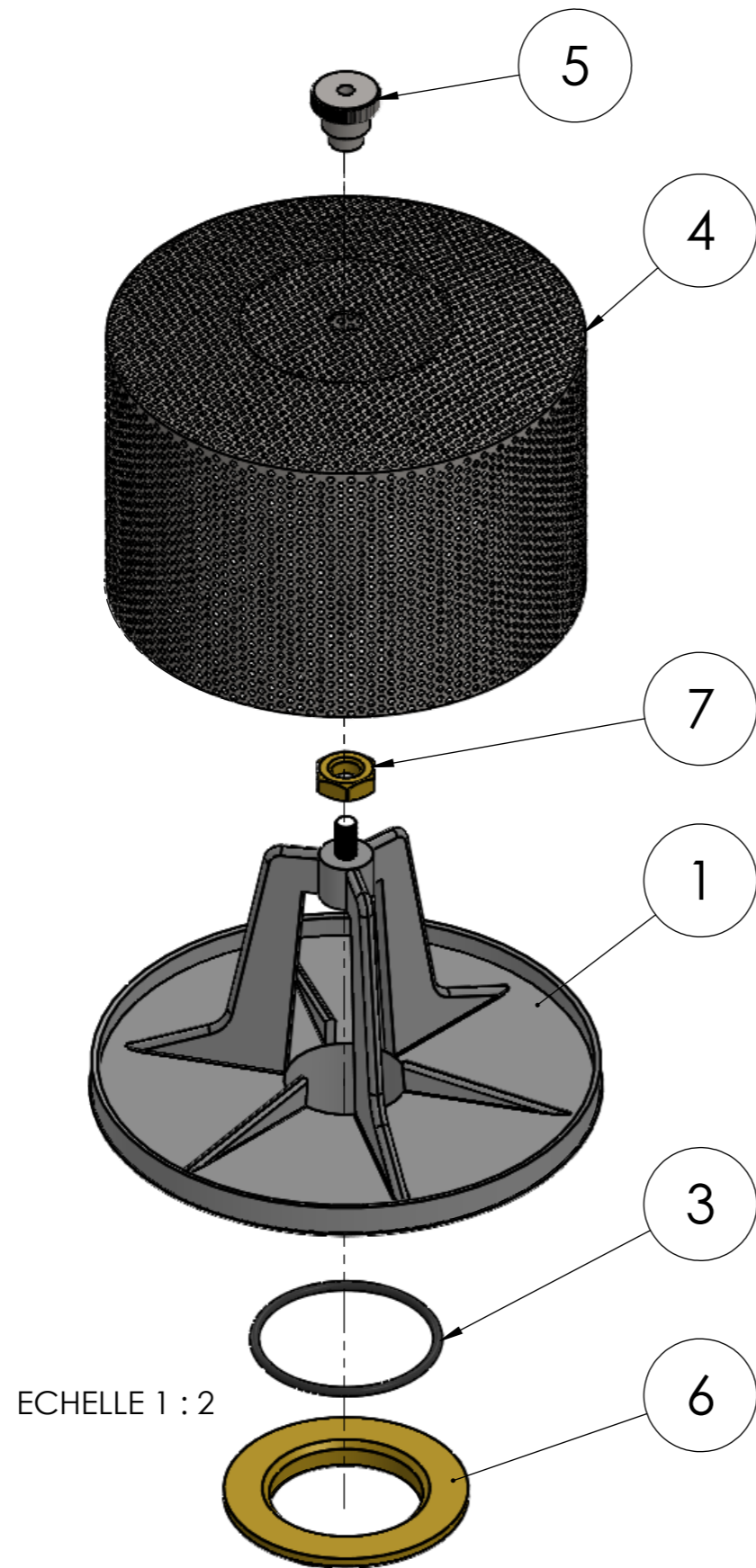

ITEM NO.	REF.	DESCRIPTION	QTE.
1	002.00.00081	BASE EN PLASTIQUE POUR FILTRE À RÉSERVOIR V-K	1
3	002.00.00093	JOINT 52X2,5	1
4	001.70.00000	FILTRE DANS LE RÉSERVOIR POUR LA POMPE V-K	1
5	001.00.00017	ECROU RÉTENTION DU FILTRE	1
6	002.00.00037	ECROU 1 1/2"	1
7	001.00.00093	M10 ECROU INOX	1



ECHELLE 1 : 2

ITEM CODE:

ITEM DESCRIPTION: FILTRE À RÉSERVOIR V-K COMPLET

SERIES DESCRIPTION: UNDERCOUNTER MODEL: EM-LV50

MODEL VERSION: 230V~N  
50/60Hz

MODEL CODE:004.50.00090

PAGE: 1

REVISION: 0



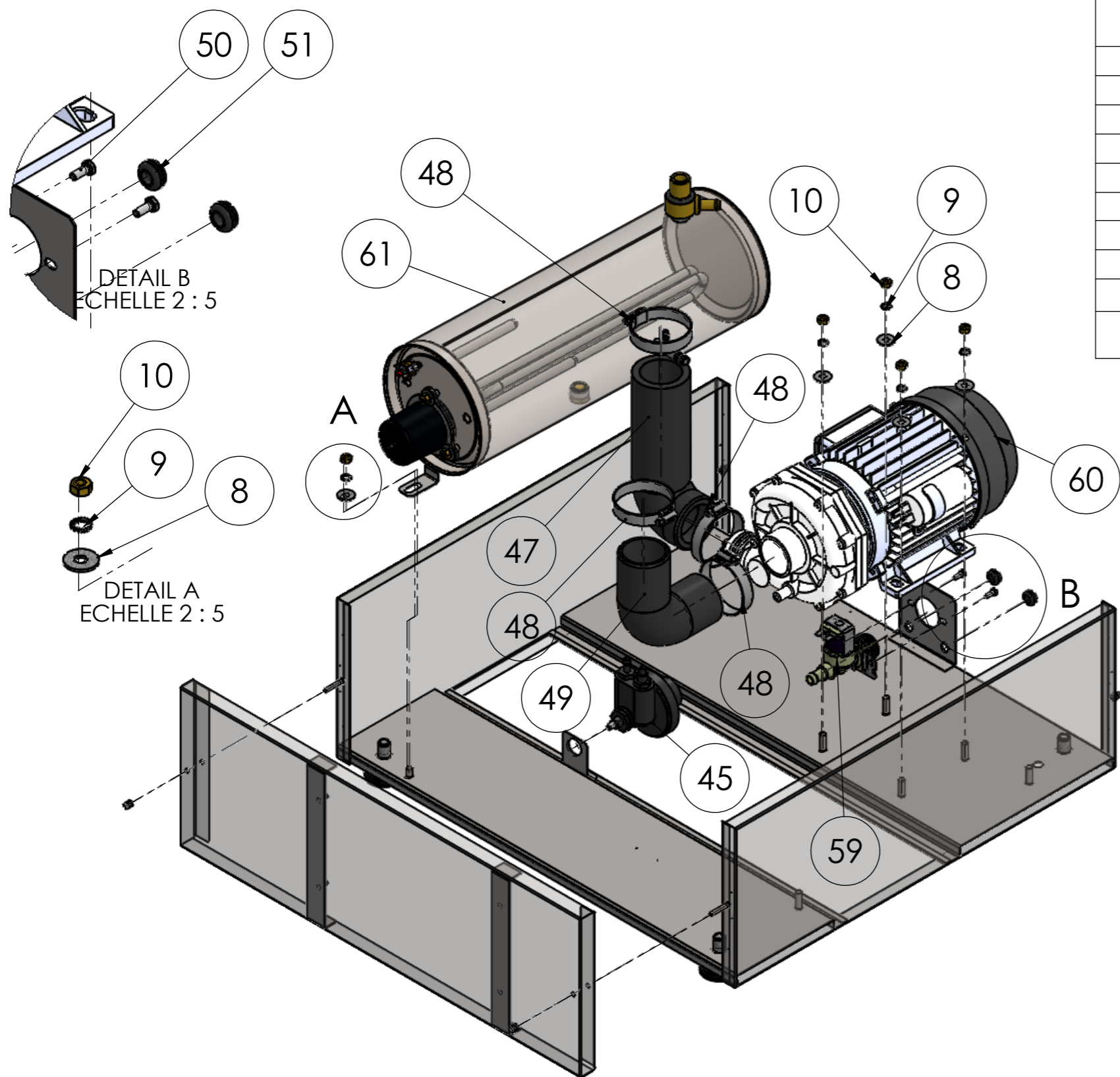

ITEM NO.	REF.	DESCRIPTION	VERGINA/ QTE.
8	003.00.00516	RONDELLE ACIER $\Phi 6 \times 18$	5
9	001.00.00204	RONDELLE GALVA 6,4x11x0,7	5
10	003.00.00041	ECROU M6 GALVANISE	5
45	003.00.00268	POMPE HYDRAULIQUE D'AIDE AU RINÇAGE	1
47	002.50.00032-1	TUYAU DE LA POMPE DE LAVAGE (SORTIE)	1
48	002.00.00050	SERRE-JOINT 40-60	4
49	002.00.00127-1	TUYAU DE LA POMPE DE LAVAGE (ENTRÉE)	1
50	003.00.00278	BOULON GALV. M4X10	2
51	003.00.00025	PROTECTEUR DE CÂBLE EN CAOUTCHOUC	2
59	003.00.00031	VANNE D'ARRIVÉE D'EAU	1
60	003.00.00350	POMPE 0,75Hp 50Hz 230V IP44	1
61	006.50.00001	SURCHAUFFEUR COMPLET AVEC ELEMENT CHAUFFANT V500	1

ITEM CODE:	ITEM DESCRIPTION: EQUIPEMENT MECANIQUE
SERIES DESCRIPTION: UNDERCOUNTER	MODEL: EM-LV50
MODEL VERSION: 230V ~ N 50/60Hz	MODEL CODE:004.50.00090
	PAGE: 2
	REVISION: 0



ITEM NO.	REF.	DESCRIPTION	230V/QTE
1	001.50.00017	SURCHAUFFEUR V500 Ø140X400	1
2	002.50.00001	SURCHAUFFEUR DE BASE DE SORTIE V500	1
3	002.00.00076	BOUCHON FILETÉ DE VIDANGE DE SURCHAUFFEUR	1
4	003.00.00260	BASE DE MONTAGE DES ÉLÉMENTS DE SURCHAUFFEUR	1
5	003.50.00005	ELEMENT CHAUFFANT SURCHAUFFEUR 3kW / 230V /	1
6	003.00.00516	RONDELLE ACIER Ø6X18	3
7	003.00.00041	ECROU M6 GALVANISE	3
8	003.00.00180	SURCHAUFFEUR THERMOFUSE 105°C	1
9	002.00.00090	ECROU GALV. M3	2
10	001.00.00204	RONDELLE GALVANISE 6,4x11x0,7	3
11	003.00.00004	COUVERCLE DE L'ÉLÉMENT CHAUFFANT	1

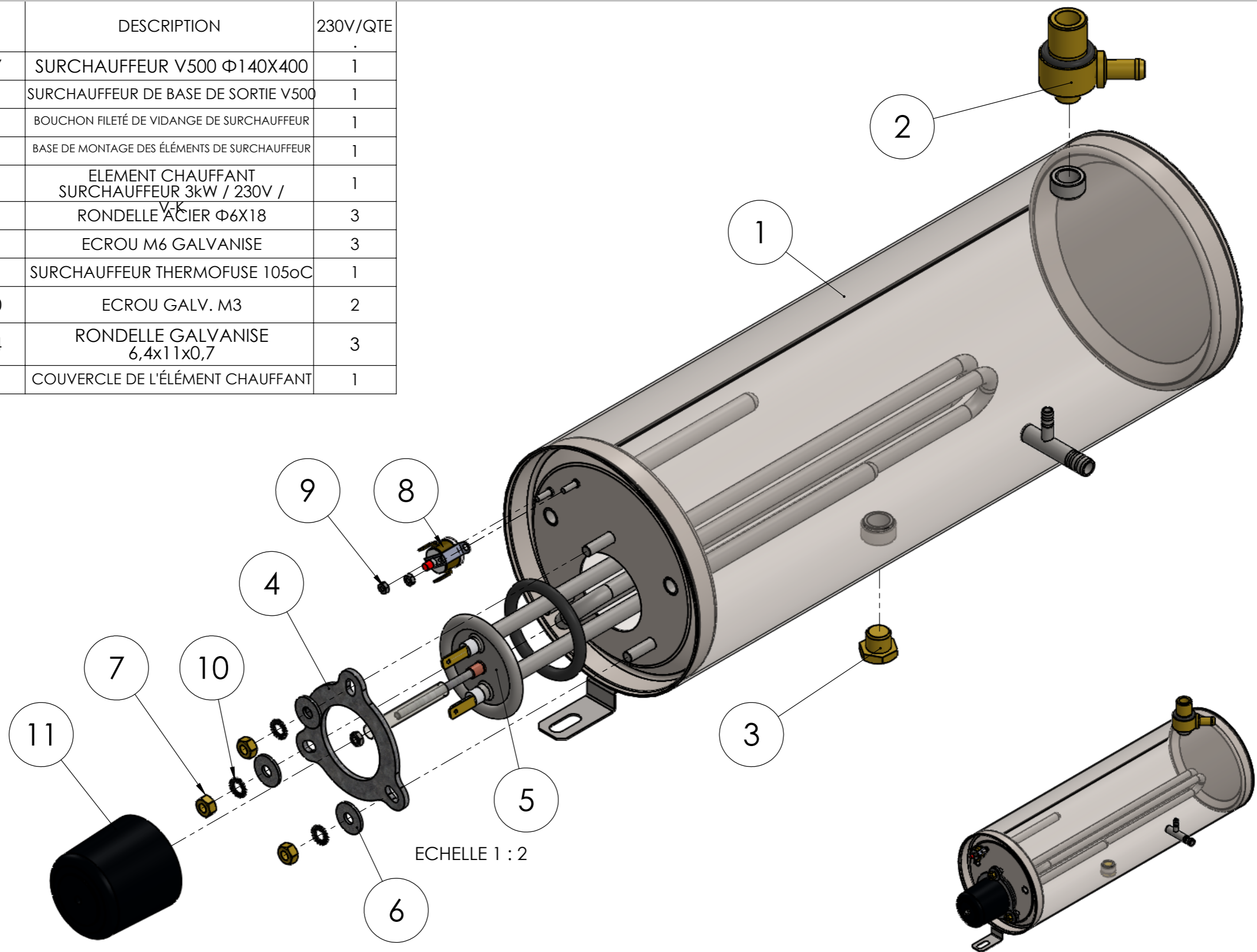

ITEM CODE: 006.50.00001

MODEL VERSION: 230V~N  
50/60Hz

ITEM DESCRIPTION: SURCHAUFFEUR COMPLET AVEC ELEMENT  
CHAUFFANT V500

MODEL CODE: 004.50.00090

SERIES DESCRIPTION: UNDERCOUNTER MODEL: EM-LV50

PAGE: 1

REVISION: 0