

INDICE	REP.	Modifications	DATE	NOM
A	.	Création plan 09 167-02	23/06/09	NM

SECTION
A-A

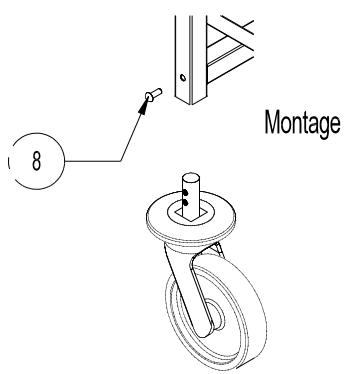

SECTION
B-B

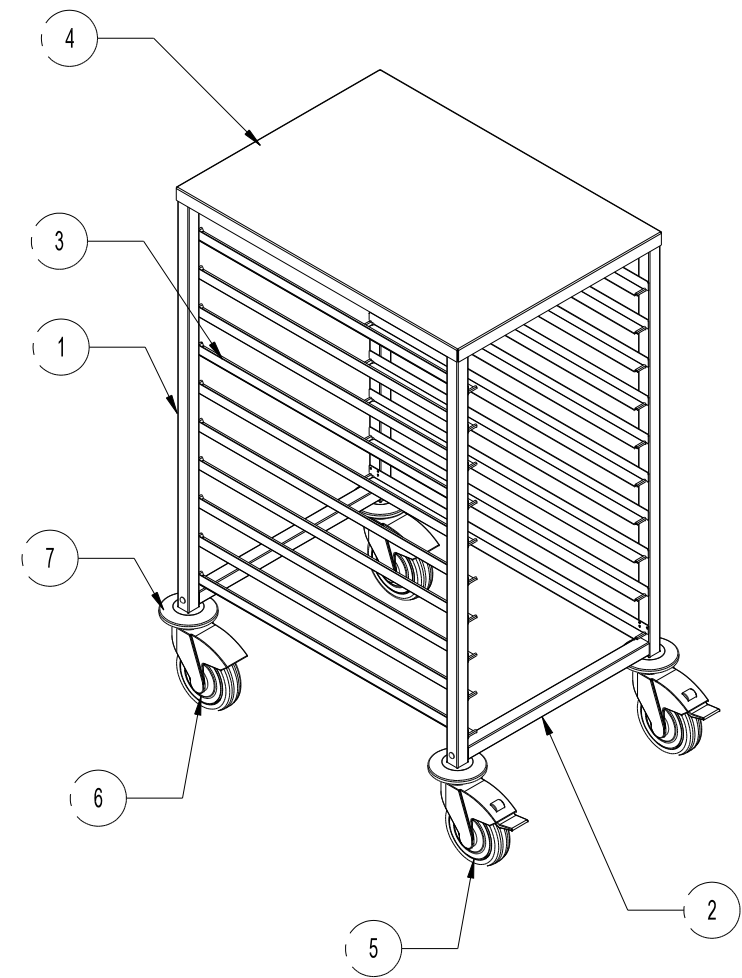
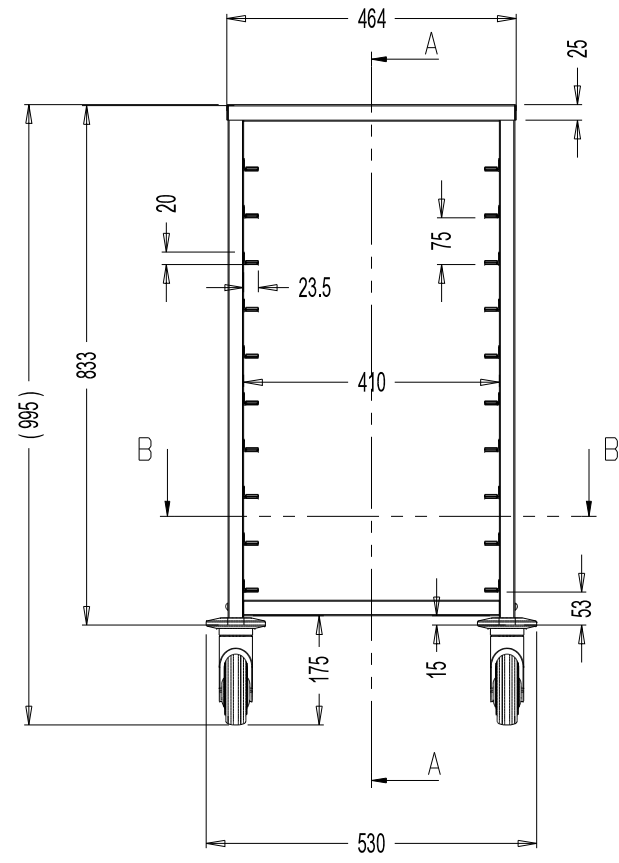
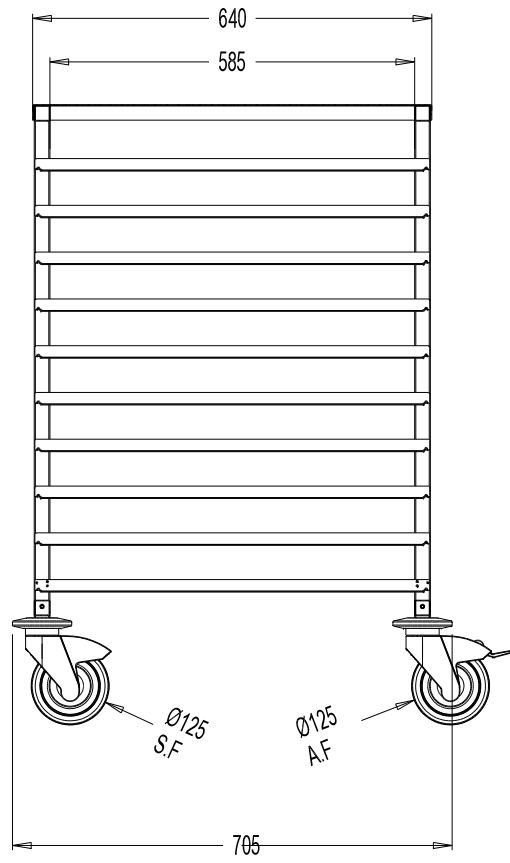
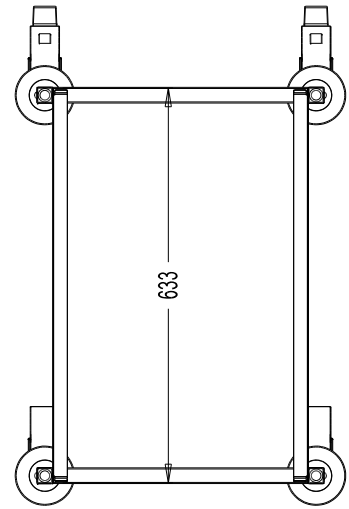

Nb	Designation	Dimension	Quantité	Référence
8	VIS TB M6*16 TORX		4	VIS000053
7	BUTOIR		4	RLTB000001
6	ROULETTE A OEIL S.F	Ø125	2	RLTP000013
5	ROULETTE A OEIL A.F	Ø125	2	RLTP000014
4	BAC TOLE Epr. 1.5	640*464	1	FPSTR71235
3	GLISSIERE AVEC BUTEES 23.5*20*1.2	633	20	FPSTR70879
2	TUBE 25*25*1.2	410	4	FPT04C2512
1	TUBE 25*25*1.2	833	4	FPT04C2512

Repère	Designation	Nb	Dimension	Référence
	CHARIOT G/P 600x400 - ENTREE 400 - PAS 75 10 NIVEAUX + PLAN DE TRAVAIL - Ht 995			Dessiné par: L. CARTELLI Le: 16 Juin 09
	Référence: SCHB6040-10		Indice: A	Poids théorique: 15 Kg
	Matière: ACIER AUSTENITIQUE			Traitement: DECAPE - PASSIVE

< 500 mm	± 1
500 - 1000 mm	± 2
> 1000 mm	± 5
∥ ⊥	± 2

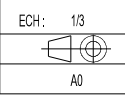

ECH: 1/3