

INDEX	REP.	Modification	DATE	NOM
A	.	CREATION	.	.
B	.	HT 1890 -> 1790	27/09/11	NR
C	.	2 ROULETTES AF	01/10/14	NR

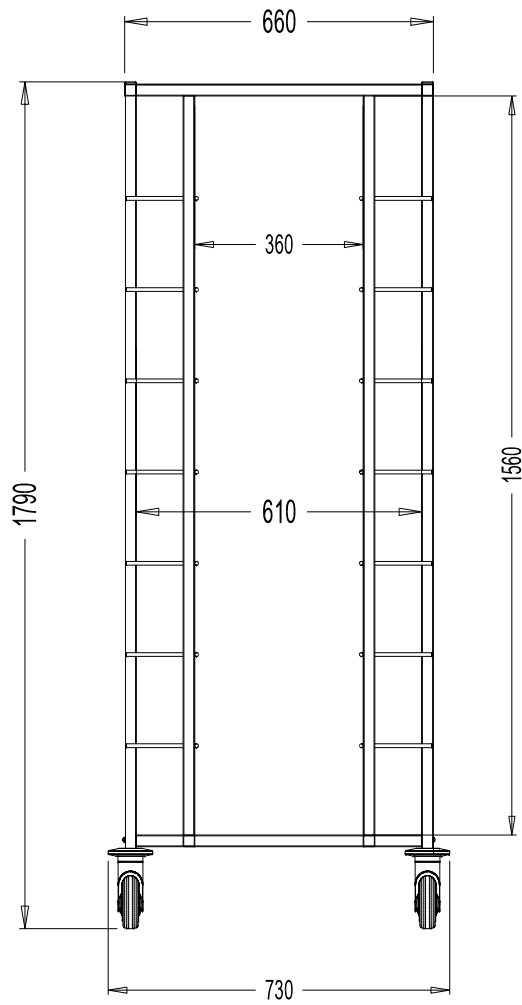

SECTION A-A

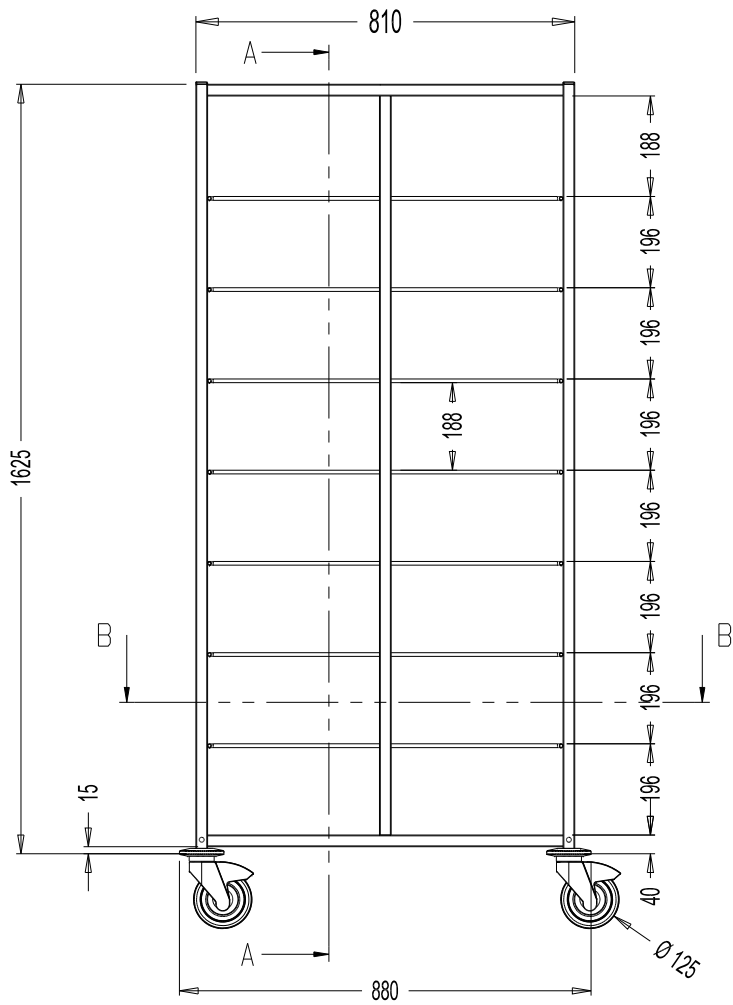
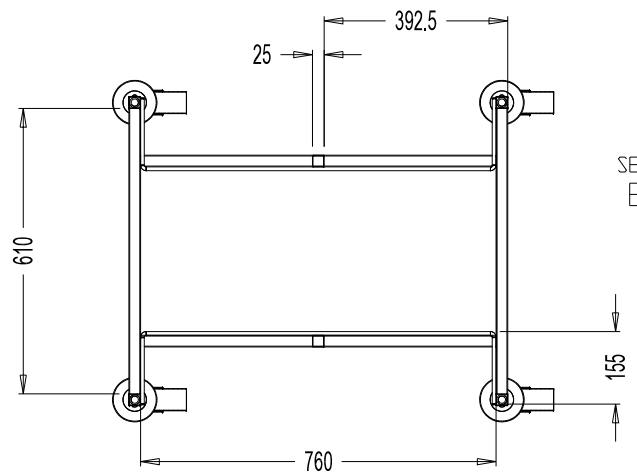
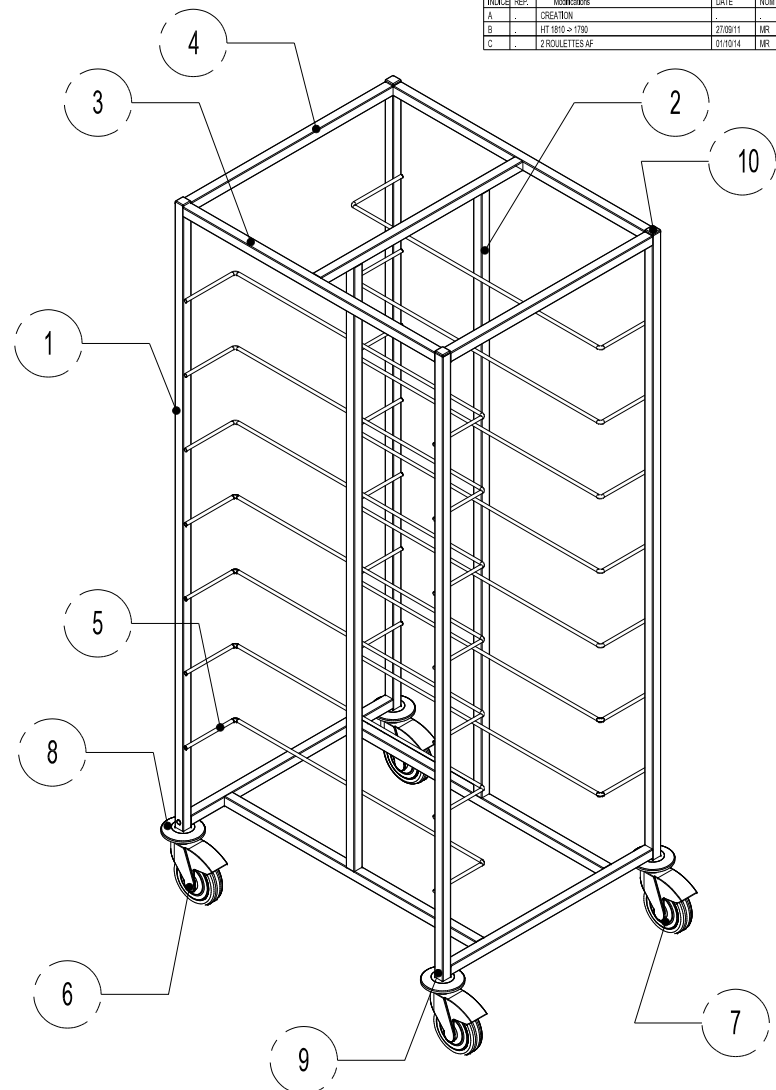

SECTION B-B

Repère	Désignation	Nb	Dimension	Référence
10	EMBOUT CARRE NOIR	4	25x25	DIV000008
9	VIS TB M6x16 TORX	4	.	VISV000053
8	BUTOIR	4	.	RLTB000001
7	ROULETTE AVEC FREIN	2	Ø 125	RLTP000012
6	ROULETTE SANS FREIN	2	Ø 125	RLTP000011
5	GLISSIERE FIL Ø8 - U 155*760*155 Chanf.	14	1054	FILMPCU078
4	TUBE 25x25x1.2	5	610	RPT01C2512
3	TUBE 25x25x1.2	4	760	RPT01C2512
2	TUBE 25x25x1.2	2	1560	RPT01C2512
1	TUBE 25x25x1.2	4	1625	RPT01C2512

< 500 mm	± 1	ECH: 1/3	<b>CHARIOT PORTE BASSINES 600 x 800</b> <b>8 NIVEAUX DOUBLE</b>		Dessiné par:
500 - 1000 mm	± 2				Le: 09 Juillet 10
> 1000 mm	± 5				Référence: CHDIV12347
	2	A0	Matériau: ACIER INOX AUSTENITIQUE	Traitement: Brossé	