

1. Product overview

ECS-11neo\ECS-2011neo\ECS-6011neo is a universal-type temperature controller with free switch between Fahrenheit and Celsius. It has two channels of temperature sensors at maximum for adjusting cabinet temperature and controlling defrost. It can be set to display the temperature value read by cabinet or evaporator sensor. With copy card function, the controller is convenient for professional equipment manufacturers in production and after-sales service.

2. Operation and display panel



3. Specification

Mounting size: 71 × 29 (mm)

Product size: 78.5 × 34.5 × 74 (mm) (ECS-2011neo)

Product size: 78.5 × 34.5 × 82 (mm) (ECS-11neo)

Product size: 78.5 × 34.5 × 41 (mm) (ECS-6011neo)

4. Technical parameters

- 1) Temperature measuring range: -50°C~90°C or -58°F~194°F (Only when sensor calibration value is set to 0.)
- 2) Temperature control range: -50°C~90°C or -58°F~194°F
- 3) Temperature resolution: 1°C or 1°F
- 4) Temperature accuracy: ±1°C (-40°C~50°C); ±2°C (51°C~70°C); ±3°C (others); or ±2°F (-40°F~122°F); ±4°F (123°F~158°F); ±6°F (others)
- 5) Power supply: 220V, 50/60Hz
- 6) Overall power consumption: <3W
- 7) Output capacity:
Cooling relay: 30A/240VAC, normally open, directly drive load of single-phase 1.5HP (220VAC);
or (optional) 17A/240VAC, normally open, directly drive load of single-phase 1HP(220VAC);
or (optional) 10A/240VAC, normally open;
Defrost or light relay (optional) : 10A/240VAC, normally open, drive electric heating wire with maximum power of 1200W (220VAC)
Note: Adjust the parameter item U3 to select the output function of defrost or light relay.
When U3=00, defrost or light relay outputs as defrost relay and the controller does not have light control function at the moment.
When U3=01, defrost or light relay outputs as light relay and the controller performs light logic function; meanwhile, the controller defrosts by shutting down compressor.
- 8) Input port: cabinet temperature sensor, evaporator sensor (optional)
- 9) Protection level of front panel: IP65
- 10) Operating ambient temperature: 0°C~55°C
- 11) Storage temperature: -25°C~75°C
- 12) Storage humidity: 20%~85% (non-condensing)

5. Indicator status

| Indicator | Symbol | Status | Meaning |
|-----------|--------|--------|-------------------------|
| Set | set | On | Set parameters |
| | | Off | Measuring & controlling |
| Cooling | | On | Cooling starts. |
| | | Off | Cooling stops. |
| | | Flash | Cooling delays. |
| Defrost | | On | Defrosting |
| | | Off | Defrost stops. |

6. Parameter list

| Menu | Function | Setting range | Default | Unit |
|------|---|---------------|---------|-------|
| St | Temperature set-point | C5 ~ C6 | 4°C | °C/°F |
| Po | Administrator menu password | 0 ~ 99 | 55 | / |
| C1 | Temperature differential | 1 ~ 15°C | 4°C | °C/°F |
| | | 1 ~ 30°F | | |
| C2 | The minimum interval of two successive switch-ons of the compressor | 1 ~ 60 | 3 | min |

| Menu | Function | Setting range | Default | Unit |
|------|--|---|---------|-------|
| C4 | Calibration temperature 1. Temp value added to the value read by cabinet sensor | -10 ~ +10°C | 0°C | °C/°F |
| | | -20 ~ +20°F | | |
| C5 | Lower set-point. Min possible set-point | -50°C ~ (C6-1) -58°F ~ (C6-1) | 2 | °C/°F |
| C6 | Higher set-poin. Max possible set-point | (C5+1) ~ +90°C (C5+1) ~ 194°F | 8 | °C/°F |
| d1 | Select evaporator sensor | 0: Disable 1: Enable | 1 | / |
| d2 | Calibration temperature 2. Temp value added to the value read by evaporator sensor. | -10 ~ +10°C | 0°C | °C/°F |
| | | -20 ~ +20°F | | |
| d4 | Defrost interval time. Interval between the start of two consecutive defrost cycles | 0 ~ 60 0: Cancel defrost function | 12 | 30min |
| d7 | Maximum defrost time | 1 ~ 99 | 20 | min |
| d8 | Defrost stop temperature | 0 ~ 45°C | 7°C | °C/°F |
| | | 32 ~ 115°F | | |
| A1 | Compressor run in duty cycle mode | 00: Disable 01: Enable | 01 | / |
| A2 | On time (compressor). Compressor activation time in the event of faulty probe. | 01 ~ 60 | 10 | min |
| A3 | OFF time (compressor). Compressor in disabled state time in the event of a faulty probe. | 01 ~ 60 | 20 | min |
| A4 | Buzzer switch | 0: Disable buzzer beeping 1: Enable buzzer beeping | 0 | / |
| A5 | Lower alarm. Max temp alarm value. | -50°C ~ A6 | -50°C | °C/°F |
| | | -58°F ~ A6 | | |
| A6 | Higher alarm. Min temp alarm value | A5 ~ 90°C | 90°C | °C/°F |
| | | A5 ~ 194°F | | |
| A7 | Temperature alarm override | 0 ~ 60 | 20 | min |
| A8 | Power-on alarm override | 0 ~ 60 | 40 | min |
| cd1 | Condenser sensor selection | 0:Disabled 1:Enabled | 1 | / |
| cd2 | Condenser high temperature alarm start value | 30°C ~ 90°C | 55°C | °C/°F |
| | | 86°F ~ 194°F | | |
| cd3 | Lower hysteresis of condenser high temperature alarm | 1°C ~ 15°C | 5°C | °C/°F |
| | | 2°F ~ 30°F | | |
| cd4 | When condenser high temperature alarm occurs, compressor work state select | 00: Unaffected; 01: compressor off | 01 | / |
| U1 | Temperature display | 00: Display the value read by cabinet sensor 01: Display the value read by evaporator sensor | 0 | / |
| U2 | Fahrenheit/Celsius ^① | 00: Fahrenheit 01: Celsius | 01 | / |
| U3 | Select defrost or light relay function ^② | 00: Defrost output 01: Light output | 00 | / |

Note ①: After switch between Celsius/Fahrenheit, the temperature set-point of parameter item St automatically adjusts to the corresponding temperature value of Celsius/Fahrenheit, and the temperature set-points of other parameter items related to Celsius/Fahrenheit automatically adjust accordingly. For example, St is set to 0°C, and it will automatically adjust to 32°F after switch; C4 (calibration temperature 1) is set to +8°C, and it will automatically adjust to +20(8/10)=+16°F.*

Suggestion: Switch Celsius/Fahrenheit first, then adjust the value of related parameter items to ensure correct parameter configuration.

Note ②: When U3=00, i.e. the defrost or light relay outputs as defrost relay and the controller does not have light function. When U3=01, i.e. the defrost or light relay outputs as light relay and the controller has light function; meanwhile, the controller defrosts by shutting down compressor. When the parameter U3 is being switched, the relay K2 keeps the status before switch.

Note ③: The default parameters are subject to change without notice.

7. Buttons

| Button name | Function | Action |
|-------------|---|------------------|
| | Set parameters | Press for 3 sec. |
| | Switch between menu and parameters | Press |
| | Adjust menu and parameters | Press |
| | Turn on/off light | Press |
| | Upload parameters to the copy card | Press for 3 sec. |
| | Adjust menu and parameters | Press |
| | Download parameters to the copy card | Press for 3 sec. |
| | View the temperature value of evaporator sensor | Press |
| | Exit setting parameters | Press |
| | Force defrost to start defrost | Press for 3 sec. |

7.2 Operation of buttons

1) Adjust parameters

Press the Set button for 3 sec in status of measuring and controlling to enter user menu, the panel will display St. Press the Set button again to display the parameter value of St, and modify the temperature set-point by pressing or .

When St shows, press to display Po, and press Set to display 00; at this moment, use the button or to input the password of administrator menu.

After inputting the password, press Set to display Po. The controller will automatically verify whether the password is correct. When it passes verification, press or to select parameter items St, Po, C1, C2.....U3 (i.e. any parameter item of user menu and administrator menu); otherwise, the controller will only stay at the parameter items St and Po without displaying other parameter items.

After selecting the menu, press Set to enter the current menu and set its parameters. Use or to adjust parameter values, then press Set again to return to menu selection status.

Under any parameter setting status, press or press no button for 30 sec to exit parameter setting and save the current parameter value automatically.

Note: The password of administrator menu is valid for once. After exiting parameter settings by pressing , correct password must be entered again before adjusting parameters.

2) View temperature

When U1 (temperature display)=00, the controller displays the current temperature read by cabinet sensor.

When U1=01, the controller displays the current temperature read by evaporator sensor.

Under status of measuring and controlling, press to view the measured temperature value of evaporator sensor (When the evaporator sensor is enabled and normal.)

3) Manually force defrosting

Under status of measuring and controlling, press for 3 sec and force defrost to start or stop.

When U3=01, i.e. the defrost or light relay outputs as light relay, press to turn on or off the light.

4) Copy card

Upload (copy the parameters in the controller to copy card)

- ① Use buttons to set parameters.
- ② Insert copy card, press until the panel displays “uP”.
- ③ Remove copy card after 3 sec and then power on the controller again.

Download (copy the parameters in copy card to the controller)

- ① Insert copy card, press until the panel displays “do”.
- ② Remove copy card and power on the controller again after 3 sec.

Note: The display of “Er” indicates programming failure. Check whether the copy card is connected and repeat the above operation.

The display of “EP” indicates that the data in the copy card is not consistent with the controller model and programming fails. Please use correct copy card or upload data to the copy card again. Then repeat the above operation.

(★ Please keep a stable power supply and effective connection of copy card in the process. Do not remove the copy card before completely finishing the operation.)

8. Control output

8.1 Cooling:

In normal status:

Cooling starts when the cabinet temperature > temperature set-point (St) + control differential (C1), and the indicated time must elapse between two successive minimum switch-ons of the compressor.

Cooling stops when the cabinet temperature < temperature set-point (St).

In case of cabinet sensor fault,

When A1=0, compressor run in duty cycle mode is disabled, cooling stops.

When A1=1, compressor run in duty cycle mode is enabled, cooling runs in duty cycle according to the set On time (compressor) (A2) and Off time (compressor) (A3) time.

8.2 Defrost:

1) d4=0, defrost is disabled.

2) d4≠0,

- ① Evaporator sensor is enabled (d1=1), and the temperature of evaporator sensor > defrost stop temperature (d8), defrost cannot start.
- ② Evaporator sensor is enabled (d1=1), and the temperature of evaporator sensor < defrost stop temperature (d8), or evaporator sensor is disabled (d1=0), defrost starts under any one of the following conditions:
 - a. When defrost interval time (d4) elapses, defrost starts.
 - b. Press for 3 seconds to start defrosting.

3) During defrosting (defrost stops under any one of the following conditions):

- ① Evaporator sensor is enabled (d1=1), and the temperature of evaporator sensor > defrost stop temperature (d8), defrost stops.
- ② When the maximum defrost time (d7) elapses, defrost stops.
- ③ Press for 3 seconds to stop defrosting.

- 4) When U3=00, the defrost or light relay outputs as defrost relay and it defrosts by electric heating.
- When U3=01, there is no defrost relay and it defrosts by shutting down the compressor.

8.3 Light

When U3=01, the defrost or light relay outputs as light relay. Press to switch on the light and press it again to switch it off.

8.4 Alarm

The panel displays E1 when cabinet sensor is faulty. The panel displays E2 when evaporator sensor is faulty.

The panel displays E3 When condenser sensor is faulty.

Condenser high temperature alarm: If the condenser sensor is selected, when the condenser temperature is higher than the condenser high temperature alarm start value, it will alarm and display cH. While it will not have an effect on the control output. When the temperature falls back to (the condenser high temperature alarm value-condenser high temperature alarm lower hysteresis), the alarm is released.

Higher/Lower alarm: When cabinet temperature goes above A6 and temperature alarm delay elapses, the panel displays rH. When cabinet temperature goes below A6, the alarm is canceled. When cabinet temperature goes below A5 and temperature alarm delay elapses, the panel displays rL. When cabinet temperature goes above A5, the alarm is canceled.

Note: Temperature alarm delay equals to A8 (Power-on Alarm Override) after power on for the first time and A7 (temperature Alarm Override) in other conditions.

When buzzer switch (A4)=1, the controller alarms and the buzzer beeps. The buzzer mutes when all the alarm is excluded or by pressing any button. When new alarm occurs, the buzzer beeps again.

| Displayed code | Cause |
|----------------|--|
| E1 | Cabinet sensor fault |
| E2 | Evaporator sensor fault |
| E3 | Condenser sensor failure |
| E2C | Evaporator sensor is shut down, but the measured temperature value of evaporator sensor is selected to show. |
| Er | Copy card fails in programming. |
| EP | The data in copy card is inconsistent with the controller model, so programming fails. |
| rH | Higher alarm |
| rL | Lower alarm |
| cH | Condenser high temperature alarm |

9. Wiring diagram

(Please refer to the actual product)

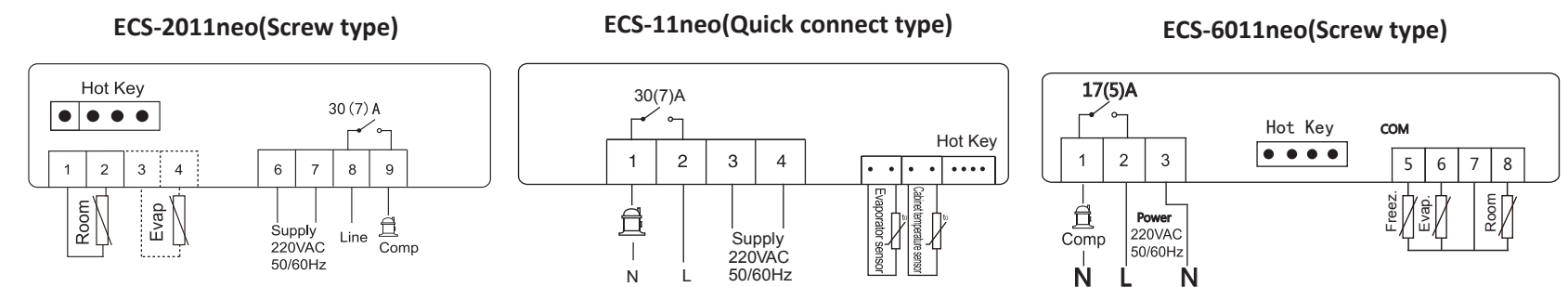

10. Safety rules

★ Danger:

- 1) Do distinguish the ports of sensor lead, power line and relays. Please do not connect lines wrong. The relay cannot be overloaded.
- 2) Wiring requires disconnection of power supply first.

★ Warning:

The controller is forbidden to be used in water or too humid environment, high temperature, strong electromagnetic interference or strong corrosion environment.

★ Notice:

- 1) The power voltage must be in accordance with the voltage labeled on the controller. Please ensure the stability of power voltage.
- 2) Suggest to keep suitable distance between sensor lead and power line to avoid possible interference.
- 3) In installing evaporator sensor, the sensor should be placed closely to the copper pipe 5 cm to the evaporator inlet. Please ensure the sensor keeps good contact with the copper pipe.